



www.herculesIndustries.com

1310 W. Evans Ave. Denver Colorado 80223

Tel. 303 937 1000 Fax. 303 937 0903

Toll Free. 1 800 356 5350

AIR INTAKE

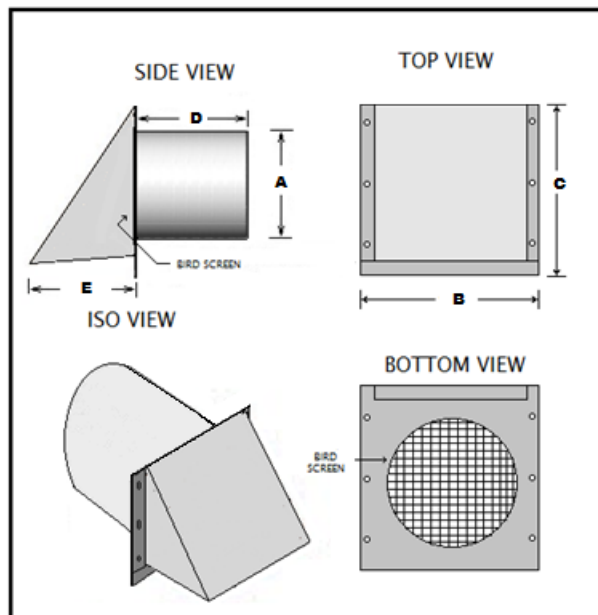

PRODUCT	A	B	C	D	E
5AI	5"	7.5"	9"	9"	3.5"
6AI	6"	8"	10"	9"	4"
7AI	7"	9"	9"	8.5"	4"
8AI	8"	10.5"	10.5"	8.5"	4.5"
10AI	10"	12"	12"	9.5"	5.5"

• Features •

Our air intakes come equipped with a ¼"x ¼" bird screen.

These items are generally used to provide fresh air to concealed areas. Not recommended for dryer vents.

Body constructed of **26Ga.** Galvanized Steel ASTM-A653-00 SMACNA Standards

* All gauges and reinforcements are in compliance with 2005 SMACNA standards for duct fabrication.

