



# **SINGLE ZONE HIGH EFFICIENCY, STANDARD, EXTENDED PIPE, AND MEGA WALL MOUNTED INSTALLATION MANUAL**



Single Zone High Efficiency:

LS091HSV3, LS121HSV3, LS181HSV3, LS240HSV3

Single Zone Standard: LS307HV3, LS360HV3

Single Zone Extended Pipe: LS240HLV, LS300HLV, LS360HLV

Single Zone Mega: LS090HEV, LS120HEV, LS180HEV, LS240HEV;

LS090HEV1, LS120HEV1, LS180HEV1, LS240HEV1

Single Zone Mega 115V: LS090HXV, LS120HXV

## **PROPRIETARY DATA NOTICE**

This document, as well as all reports, illustrations, data, information, and other materials are the property of LG Electronics U.S.A., Inc., and are disclosed by LG Electronics U.S.A., Inc., only in confidence.

This document is for design purposes only.

**Do not throw away, destroy, or lose this manual.**

Please read carefully and store in a safe place for future reference.

Content familiarity required for proper installation.

The instructions included in this manual must be followed to prevent product malfunction, property damage, injury, or death to the user or other people. Incorrect operation due to ignoring any instructions will cause harm or damage. The level of seriousness is classified by the symbols described below.

A summary list of safety precautions begins on page 3.

IM\_WallMounted\_All\_11\_15

For more technical materials such as submittals, engineering databooks, and catalogs, visit [www.lghvac.com](http://www.lghvac.com).

For continual product development, LG Electronics U.S.A., Inc., reserves the right to change specifications without notice.





©LG Electronics U.S.A., Inc.

*This document, as well as all reports, illustrations, data, information, and other materials are the property of LG Electronics U.S.A., Inc.*

# SAFETY INSTRUCTIONS

The instructions below must be followed to prevent product malfunction, property damage, injury or death to the user or other people. Incorrect operation due to ignoring any instructions will cause harm or damage. The level of seriousness is classified by the symbols described below.

## TABLE OF SYMBOLS

 <b>DANGER</b>	<i>This symbol indicates an imminently hazardous situation which, if not avoided, will result in death or serious injury.</i>
 <b>WARNING</b>	<i>This symbol indicates a potentially hazardous situation which, if not avoided, could result in death or serious injury.</i>
 <b>CAUTION</b>	<i>This symbol indicates a potentially hazardous situation which, if not avoided, may result in minor or moderate injury.</i>
<b>Note</b>	<i>This symbol indicates situations that may result in equipment or property damage accidents only.</i>
	<i>This symbol indicates an action should not be completed.</i>

## INSTALLATION

### **DANGER**

 **Don't store or use flammable gas / combustibles near the unit.**

*There is risk of fire, explosion, and physical injury or death.*

### **WARNING**

 **Do not install, remove, or re-install the unit by yourself (end user). Ask the dealer or an authorized technician to install the unit.**

*Improper installation by the user may result in water leakage, fire, explosion, electric shock, physical injury or death.*

**For replacement of an installed unit, always contact an LG trained service provider.**

*There is risk of fire, electric shock, explosion, and physical injury or death.*

**The unit is shipped with refrigerant and the service valves closed.  Do not open service valves on the unit until all non-condensibles have been removed from the piping system and authorization to do so has been obtained from the commissioning agent.**

*There is a risk of physical injury or death.*

 **Do not run the compressor with the service valves closed.**

*There is a risk of explosion, physical injury, or death.*

**Periodically check that the outdoor frame is not damaged.**

*There is a risk of explosion, physical injury, or death.*

**Replace all control box and panel covers.**

*If cover panels are not installed securely, dust, water and animals may enter the unit, causing fire, electric shock, and physical injury or death.*

**Always check for system refrigerant leaks after the unit has been installed or serviced.**

*Exposure to high concentration levels of refrigerant gas may lead to illness or death.*

**Wear protective gloves when handling equipment. Sharp edges may cause personal injury.**

**Dispose the packing materials safely.**

• *Packing materials, such as nails and other metal or wooden parts, may cause puncture wounds or other injuries.*

• *Tear apart and throw away plastic packaging bags so that children may not play with them and risk suffocation and death.*

**Install the unit considering the potential for strong winds or earthquakes.**

*Improper installation may cause the unit to fall over, resulting in physical injury or death.*

 **Do not change the settings of the protection devices.**

*If the pressure switch, thermal switch, or other protection device is shorted and forced to operate improperly, or parts other than those specified by LG are used, there is risk of fire, electric shock, explosion, and physical injury or death.*

 **Do not install the unit on a defective stand.**

*There is a risk of physical injury.*

# SAFETY INSTRUCTIONS

## INSTALLATION - CONTINUED

### ⚠ WARNING

If the air conditioner is installed in a small space, take measures to prevent the refrigerant concentration from exceeding safety limits in the event of a refrigerant leak.

Consult the latest edition of ASHRAE (American Society of Heating, Refrigerating, and Air Conditioning Engineers) Standard 15. If the refrigerant leaks and safety limits are exceeded, it could result in personal injuries or death from oxygen depletion.

Install the unit in a safe location where nobody can step on or fall onto it.



*There is risk of physical injury or death.*

**Properly insulate all cold surfaces to prevent “sweating.”**

*Cold surfaces such as uninsulated piping can generate condensate that could drip, causing a slippery surface that creates a risk of slipping, falling, and personal injury.*

### ⚠ CAUTION

Be very careful when transporting the product.

-  Do not attempt to carry the product without assistance.
- Some products use polypropylene bands for packaging.  Do not use polypropylene bands to lift the unit.
- Suspend the unit from the base at specified positions.
- Support the unit a minimum of four points to avoid slippage from rigging apparatus.

#### Note:

 **Don't install the unit where it's directly exposed to ocean winds.**

*Ocean winds may cause corrosion, particularly on the condenser and evaporator fins, which, in turn could cause product malfunction or inefficient performance.*

**When installing the unit in a low-lying area, or a location that is not level, use a raised concrete pad or concrete blocks to provide a solid, level foundation.**

*This may prevent water damage and reduce abnormal vibration.*

**Properly insulate all cold surfaces to prevent “sweating.”**

*Cold surfaces such as uninsulated piping can generate condensate that may drip and cause a slippery surface condition and/or water damage to walls.*

**When installing the unit in a hospital, mechanical room, or similar electromagnetic field (EMF) sensitive environment, provide sufficient protection against electrical noise.**

*Inverter equipment, power generators, high-frequency medical equipment, or radio communication equipment may cause the air conditioner to operate improperly. The unit may also affect such equipment by creating electrical noise that disturbs medical treatment or image broadcasting.*

 **Do not use the product for special purposes such as preserving foods, works of art, wine coolers, or other precision air conditioning applications. The equipment is designed to provide comfort cooling and heating.**

*There is risk of property damage.*

 **Do not make refrigerant substitutions. Use R410A only.**

*If a different refrigerant is used, or air mixes with original refrigerant, the unit will malfunction and be damaged.*

**Keep the unit upright during installation to avoid vibration or water leakage.**

 **Do not install the unit in a noise sensitive area.**

**When connecting refrigerant tubing, remember to allow for pipe expansion.**

*Improper piping may cause refrigerant leaks and system malfunction.*

**Take appropriate actions at the end of HVAC equipment life to recover, recycle, reclaim or destroy R410A refrigerant according to applicable U.S. Environmental Protection Agency (EPA) rules.**

**Periodically check that the outdoor frame is not damaged.**

*There is a risk of equipment damage.*

**Install the unit in a safe location where nobody can step on or fall onto it.  Do not install the unit on a defective stand.**

*There is risk of unit and property damage.*

**Install the drain hose to ensure adequate drainage.**

*There is a risk of water leakage and property damage.*

 **Don't store or use flammable gas / combustibles near the unit.**

*There is risk of product failure.*

**Always check for system refrigerant leaks after the unit has been installed or serviced.**

*Low refrigerant levels may cause product failure*

**The unit is shipped with refrigerant and the service valves closed.  Do not open service valves on the unit until all non-condensibles have been removed from the piping system and authorization to do so has been obtained from the commissioning agent.**

*There is a risk of refrigerant contamination, refrigerant loss and equipment damage.*

 **Do not run the compressor with the service valves closed.**

*There is a risk of equipment damage.*

# SAFETY INSTRUCTIONS

---

---

## WIRING

### **⚠ DANGER**

**High voltage electricity is required to operate this system. Adhere to the National Electrical Codes and these instructions when wiring.**

*Improper connections and inadequate grounding can cause accidental injury or death.*

**Always ground the unit following local, state, and National Electrical Codes.**

**Turn the power off at the nearest disconnect before servicing the equipment.**

*Electrical shock can cause physical injury or death.*

**Properly size all circuit breakers or fuses.**

*There is risk of fire, electric shock, explosion, physical injury or death.*

### **⚠ WARNING**

**The information contained in this manual is intended for use by an industry-qualified, experienced, certified electrician familiar with the U.S. National Electric Code (NEC) who is equipped with the proper tools and test instruments.**

*Failure to carefully read and follow all instructions in this manual can result in equipment malfunction, property damage, personal injury or death.*

**All electric work must be performed by a licensed electrician and conform to local building codes or, in the absence of local codes, with the National Electrical Code, and the instructions given in this manual.**

*If the power source capacity is inadequate or the electric work is not performed properly, it may result in fire, electric shock, physical injury or death.*

**Refer to local, state, and federal codes, and use power wires of sufficient current capacity and rating.**

*Wires that are too small may generate heat and cause a fire.*

**Secure all field wiring connections with appropriate wire strain relief.**

*Improperly securing wires will create undue stress on equipment power lugs. Inadequate connections may generate heat, cause a fire and physical injury or death.*

# SAFETY INSTRUCTIONS

## OPERATION

### **⚠ DANGER**

- ⊘ **Do not provide power to or operate the unit if it is flooded or submerged.**

*There is risk of fire, electric shock, physical injury or death.*

**Use a dedicated power source for this product.**

*There is risk of fire, electric shock, physical injury or death.*

### **⚠ WARNING**

- ⊘ **Do not allow water, dirt, or animals to enter the unit.**

*There is risk of fire, electric shock, physical injury or death.*

**Avoid excessive cooling and periodically perform ventilation to the unit.**

*Inadequate ventilation is a health hazard.*

- ⊘ **Do not touch the refrigerant piping during or after operation.**

*It can cause burns or frostbite.*

- ⊘ **Do not operate the unit with the panel(s) or protective cover(s) removed; keep fingers and clothing away from moving parts.**

*The rotating, hot, cold, and high-voltage parts of the unit can cause physical injury or death.*

**Periodically verify the equipment mounts have not deteriorated.**

*If the base collapses, the unit could fall and cause physical injury or death.*

### **⚠ CAUTION**

**To avoid physical injury, use caution when cleaning or servicing the air conditioner.**

#### **Note:**

**Clean up the site after installation is finished, and check that no metal scraps, screws, or bits of wiring have been left inside or surrounding the unit.**

- ⊘ **Do not use this equipment in mission critical or special-purpose applications such as preserving foods, works of art, wine coolers or refrigeration. The equipment is designed to provide comfort cooling and heating.**

*Oil, steam, sulfuric smoke, etc., can significantly reduce the performance of the unit, or damage its parts.*

**Provide power to the compressor crankcase heaters at least six (6) hours before operation begins.**

*Starting operation with a cold compressor sump(s) may result in severe bearing damage to the compressor(s). Keep the power switch on during the operational season.*

- ⊘ **Do not operate the disconnect switch with wet hands.**

*There is risk of fire, electric shock, physical injury or death.*

**If gas leaks out, ventilate the area before operating the unit.**

*If the unit is mounted in an enclosed, low-lying, or poorly ventilated area, and the system develops a refrigerant leak, it may cause fire electric shock, explosion, physical injury or death.*

**Periodically, check power cord and plug for damage.**

*Cord must be replaced by the manufacturer, its service agent, or similar qualified persons in order to avoid physical injury and/or electric shock.*

- ⊘ **Do not open the inlet grille of the unit during operation.**

- ⊘ **Do not operate the unit with the panels or guards removed.** ⊘ **Do not insert hands or other objects through the inlet or outlet when the unit is plugged in.** ⊘ **Do not touch the electrostatic filter, if the unit includes one.**

*The unit contains sharp, rotating, hot, and high voltage parts that can cause personal injury and/or electric shock.*

**Securely attach the electrical part cover to the indoor unit and the service panel to the outdoor unit.**

*Non-secured covers can result in burns or electric shock due to dust or water in the service panel.*

- ⊘ **Do not block the inlet or outlet.**

*Unit may malfunction.*

**Securely attach the electrical part cover to the indoor unit and the service panel to the outdoor unit.**

*Non-secured covers can result in malfunction due to dust or water in the service panel.*

**Periodically verify the equipment mounts have not deteriorated.**

*If the base collapses, the unit could fall and cause property damage or product failure.*

- ⊘ **Do not allow water, dirt, or animals to enter the unit.**

*There is risk of unit failure.*

# TABLE OF CONTENTS

Safety Instructions .....	3	Refrigerant Piping Connections.....	36
General Data .....	8	<i>Refrigerant Piping System Limitations</i> .....	36
<i>Unit Nomenclature</i> .....	8	<i>Installation Overview</i> .....	38
<i>Single Zone High Efficiency Unit Specifications</i> .....	9	<i>Directional Pipe Formation</i> .....	39
<i>Single Zone Standard Unit Specifications</i> .....	10	<i>Drain Hose</i> .....	40
<i>Single Zone Extended Pipe Unit Specifications</i> .....	11	<i>Outdoor Unit Connections</i> .....	41-42
<i>Single Zone Mega Unit Specifications</i> .....	12-13	<i>Indoor Unit Connections</i> .....	43
<i>Single Zone Mega 115V Unit Specifications</i> .....	14	<i>Indoor Unit Connections - Conduit Bracket Placement</i> .....	44
<i>Electrical</i> .....	15	<i>Bundling and Cutting Line</i> .....	45
<i>R410A Refrigerant</i> .....	16	<i>Refrigerant Piping Insulation</i> .....	46-48
General Installation Guidelines.....	17	<i>Air Purging</i> .....	49
<i>Location Selection</i> .....	17	<i>Leak Test/Soap Method Check</i> .....	50
<i>Oceanside Applications</i> .....	18	<i>Evacuation of Lines</i> .....	51
<i>Mounting Bolt Location</i> .....	19	<i>Finishing Up</i> .....	51
<i>Required Clearances</i> .....	19-20	<i>Remote Controller</i> .....	51
<i>Mounting of Indoor Unit Installation Plate</i> .....	21-25	<i>Pump Down, Cooling Only Mode</i> .....	52
<i>Mounting of Indoor Unit</i> .....	26	Electrical Wiring .....	53
<i>Piping Preparation</i> .....	27	<i>General Information and Safety Guidelines</i> .....	53
<i>Piping Materials and Handling</i> .....	28-33	<i>Power Wiring Specifications and Best Practices</i> .....	53-55
<i>Piping Support, Elbow Usage</i> .....	33	<i>Controllers</i> .....	55
<i>Refrigerant Piping System Layout</i> .....	35	<i>Indoor Unit Electrical Connections</i> .....	56-60
		<i>Outdoor Unit Electrical Connections</i> .....	61-65
		<i>Self Diagnosis Functions</i> .....	66-67
		<i>LG SIMS - Self Diagnosis Functions</i> .....	68-69
		Troubleshooting .....	70
		<i>Error Codes</i> .....	70-72
		<i>Refrigerant Leaks</i> .....	73
		Installation Checklist.....	74

# GENERAL DATA

## Unit Nomenclature

### Single Zone Wall Mount Indoor and Outdoor Units

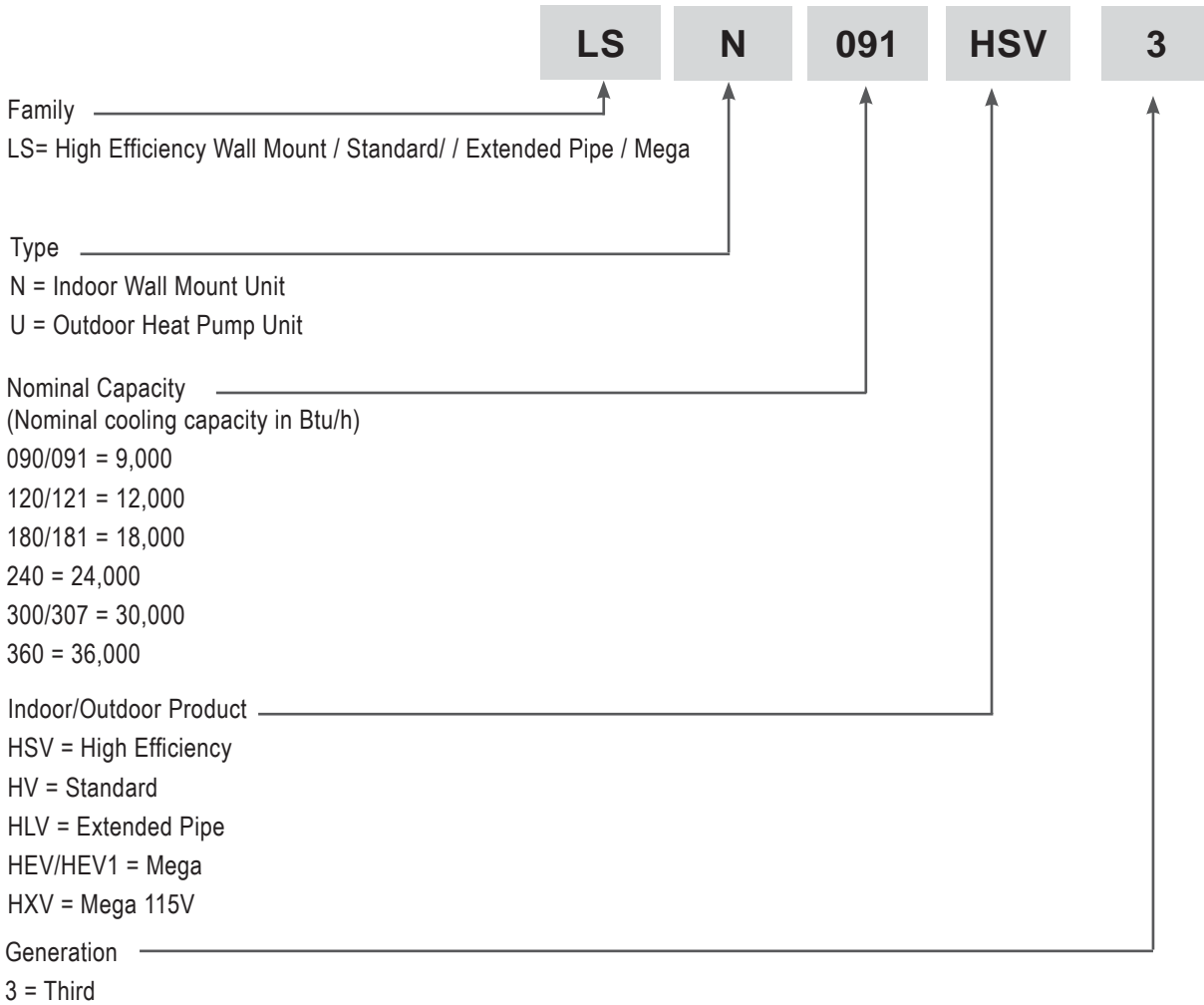



# GENERAL DATA

## Single Zone High Efficiency Unit Specifications

Table 1: Single Zone High Efficiency Unit Specifications

Type	Single Zone High Efficiency Units			
System Model Number (IDU/ODU)	LS091HSV3 (LSN091HSV3/ LSU091HSV3)	LS121HSV3 (LSN121HSV3/ LSU121HSV3)	LS181HSV3 (LSN181HSV3/ LSU181HSV3)	LS240HSV3 (LSN240HSV3/ LSU240HSV3)
Nominal Cooling Capacity (Btu/h)	9,000	11,200	18,200	22,000
Cooling Power Input <sup>1</sup> (kW)	0.67	0.89	1.4	1.7
Nominal Heating Capacity (Btu/h) <sup>1</sup>	10,800	13,300	22,000	27,600
Heating Power Input <sup>1</sup> (kW)	0.70	1.0	1.7	2.3
COP	4.53	3.90	3.66	3.4
EER	13.3	12.5	12.6	12.5
SEER	21.5	21.5	20.5	20.0
HSPF	11.0	11.0	9.7	10.2
Power Supply (V/Hz/Ø)	208-230/60/1			
<b>Outdoor Unit Operating Range<sup>2</sup></b>				
Cooling (°F DB)	14-118			
Heating (°F WB)	-4-75			
<b>Indoor Unit Operating Range<sup>2</sup></b>				
Cooling (°F)	64-90			
Heating (°F)	60-86			
<b>Unit Data</b>				
Refrigerant Type <sup>3</sup>	R410A			
Refrigerant Control	EEV			
IDU Sound Pressure <sup>4</sup> dB(A) (H/M/L)	38/33/24	39/33/24	45/40/35	46/43/39
ODU Sound Pressure <sup>4</sup> dB(A)	45	45	53	54
Power/Communication Cable <sup>5</sup> (No. x AWG)	4 x 18			
IDU Net/Shipping Weight (lbs)	23/28	23/28	32/41	36/42
ODU Net/Shipping Weight (lbs)	75/79	75/79	123/131	128/137
<b>Compressor</b>				
Compressor Type (Qty)	Rotary (1)	Rotary (1)	Twin Rotary (1)	Twin Rotary (1)
<b>Fan</b>				
IDU Type (Qty)	Cross Flow (1)			
ODU Type (Qty)	Propeller (1)			
Motor/Drive	Brushless Digitally Controlled/Direct			
<b>Airflow Rate</b>				
IDU Max/H/M/L (CFM)	388/335/272/212	423/353/272/212	735/622/509/399	883/742/629/424
ODU Max (CFM)	1,165	1,165	2,119	2,119
<b>Piping</b>				
Liquid Line (in, OD)	1/4	1/4	3/8	3/8
Vapor Line (in, OD)	3/8	3/8	5/8	5/8
Condensation Line (OD, ID)	27/32, 5/8	27/32, 5/8	27/32, 5/8	27/32, 5/8
Additional Refrigerant Charge (oz/ft)	0.22	0.22	0.38	0.38
Pipe Length <sup>6</sup> (ft) (Min./Max.)	6.6/65.6	6.6/65.6	9.8/98.4	9.8/98.4
Piping Length <sup>6</sup> (no add'l refrigerant, ft)	41.0	41.0	24.6	24.6
Max Elevation Difference (ft)	32.8	32.8	49.2	49.2

EEV: Electronic Expansion Valve IDU: Indoor Unit ODU: Outdoor Unit

<sup>1</sup>Power Input is rated at high speed.

<sup>2</sup>Low Ambient Wind Baffle Kit allows operation down to 0°F in cooling mode.

<sup>3</sup>Take appropriate actions at the end of HVAC equipment life to recover, recycle, reclaim or destroy R410A refrigerant according to applicable regulations (40 CFR Part 82, Subpart F) under section 608 of CAA.

<sup>4</sup>Sound Pressure levels are tested in an anechoic chamber under ISO Standard 1996.

<sup>5</sup>Power/communication cables from the outdoor unit to the indoor unit to be minimum 18 AWG, 4-conductor, stranded, shielded or unshielded (if shielded, it must be grounded to the chassis at the outdoor unit only) and must comply with applicable and national code.

<sup>6</sup>Piping lengths are equivalent.

Power wiring to the outdoor unit is field supplied, solid or stranded, and must comply with the applicable local and national codes.

This unit comes with a dry helium charge.

This data is rated 0 ft above sea level with 24.6 of refrigerant line per indoor unit and a 0 ft level difference outdoor and indoor units.

Cooling capacity rating obtained with air entering the indoor unit at 80°F dry bulb (DB) and 67°F wet bulb (WB) and outdoor ambient conditions of 95°F dry bulb (DB) and 75°F wet bulb (WB).

Heating capacity rating obtained with air entering the indoor unit at 70°F dry bulb (DB) and 59°F wet bulb (WB) and outdoor ambient conditions of 47°F dry bulb (DB) and 43°F wet bulb (WB).

# GENERAL DATA

## Single Zone Standard Unit Specifications

Table 2: Single Zone Standard Unit Specifications

Type System Model Number (IDU/ODU)	Single Zone Standard Units	
	LS307HV3 (LSN307HV3/LSU307HV3)	LS360HV3 (LSN360HV3/LSU360HV3)
Nominal Cooling Capacity (Btu/h)	30,000	33,000
Cooling Power Input <sup>1</sup> (kW)	3.0	4.0
Nominal Heating Capacity (Btu/h) <sup>1</sup>	32,000	35,200
Heating Power Input <sup>1</sup> (kW)	3.1	3.8
COP	3.0	2.7
EER	10.0	8.2
SEER	18.0	16.1
HSPF	9.5	9.9
Power Supply (V/Hz/Ø)	208-230/60/1	208-230/60/1
<b>Outdoor Unit Operating Range</b>		
Cooling (°F DB)	14-118	14-118
Heating (°F WB)	-4-75	-4-75
<b>Indoor Unit Operating Range</b>		
Cooling (°F)	64-90	64-90
Heating (°F)	60-86	60-86
<b>Unit Data</b>		
Refrigerant Type <sup>2</sup>	R410A	R410A
Refrigerant Control	EEV	EEV
IDU Sound Pressure <sup>3</sup> dB(A) (H/M/L)	49/44/39	49/44/39
ODU Sound Pressure <sup>3</sup> dB(A)	55	55
Power/Communication Cable <sup>4</sup> (No. x AWG)	4 x 18	4 x 18
IDU Net/Shipping Weight (lbs)	36/42	36/42
ODU Net/Shipping Weight (lbs)	128/137	128/137
<b>Compressor</b>		
Compressor Type (Qty)	Twin Rotary (1)	Twin Rotary (1)
<b>Fan</b>		
IDU Type (Qty)	Cross Flow	Cross Flow
ODU Type (Qty)	Propeller	Propeller
Motor/Drive	Brushless Digitally Controlled/Direct	
<b>Airflow Rate</b>		
IDU Max/H/M/L (CFM)	883/770/629/424	883/795/629/424
ODU Max (CFM)	2,119	2,119
<b>Piping</b>		
Liquid Line (in, OD)	3/8	3/8
Vapor Line (in, OD)	5/8	5/8
Condensation Line (OD/ID)	27/32, 5/8	27/32, 5/8
Additional Refrigerant Charge (oz/ft)	0.38	0.38
Pipe Length <sup>5</sup> (ft) (Min./Max.)	9.8/98.4	9.8/98.4
Piping Length <sup>5</sup> (no add'l refrigerant, ft)	24.6	24.6
Max Elevation Difference (ft)	49.2	49.2

EEV: Electronic Expansion Valve IDU: Indoor Unit ODU: Outdoor Unit

<sup>1</sup>Power Input is rated at high speed.

<sup>2</sup>Take appropriate actions at the end of HVAC equipment life to recover, recycle, reclaim or destroy R410A refrigerant according to applicable regulations (40 CFR Part 82, Subpart F) under section 608 of CAA.

<sup>3</sup>Sound Pressure levels are tested in an anechoic chamber under ISO Standard 1996.

<sup>4</sup>Power/communication cables from the outdoor unit to the indoor unit to be minimum 18 AWG, 4-conductor, stranded, shielded or unshielded (if shielded, it must be grounded to the chassis at the outdoor unit only) and must comply with applicable and national code.

<sup>5</sup>Piping lengths are equivalent.

Power wiring to the outdoor unit is field supplied, solid or stranded, and must comply with the applicable local and national codes.

This unit comes with a dry helium charge.

This data is rated 0 ft above sea level with 24.6 of refrigerant line per indoor unit and a 0 ft level difference outdoor and indoor units.

Cooling capacity rating obtained with air entering the indoor unit at 80°F dry bulb (DB) and 67°F wet bulb (WB) and outdoor ambient conditions of 95°F dry bulb (DB) and 75°F wet bulb (WB).

Heating capacity rating obtained with air entering the indoor unit at 70°F dry bulb (DB) and 59°F wet bulb (WB) and outdoor ambient conditions of 47°F dry bulb (DB) and 43°F wet bulb (WB).

# GENERAL DATA

## Single Zone Extended Pipe Unit Specifications

Table 3: Single Zone Extended Pipe Unit Specifications

Type	Single Zone Extended Pipe Units		
System Model Number (IDU/ODU)	LS240HLV (LSN240HLV/LSU240HLV)	LS300HLV (LSN300HLV/LSU300HLV)	LS360HLV (LSN360HLV/LSU360HLV)
Nominal Cooling Capacity (Btu/h)	22,000	30,000	33,000
Cooling Power Input <sup>1</sup> (kW)	1.7	3.0	4.0
Nominal Heating Capacity (Btu/h) <sup>1</sup>	27,000	32,000	35,200
Heating Power Input <sup>1</sup> (kW)	2.3	3.1	3.8
COP	3.32	3.03	2.69
EER	12.5	10.0	8.2
SEER	21.0	18.5	16.5
HSPF	11	10	10
Power Supply (V/Hz/Ø)	208-230/60/1		
<b>Outdoor Unit Operating Range</b>			
Cooling (°F DB)	14-118		
Heating (°F WB)	-4-65		
<b>Indoor Unit Operating Range</b>			
Cooling (°F)	53-75		
Heating (°F)	60-86		
<b>Unit Data</b>			
Refrigerant Type <sup>2</sup>	R410A		
Refrigerant Control	EEV		
IDU Sound Pressure <sup>3</sup> dB(A) (H/M/L)	49/44/40	49/44/40	49/44/40
ODU Sound Pressure <sup>3</sup> dB(A)	55	55	55
Power/Communication Cable <sup>4</sup> (No. x AWG)	4 x 18		
IDU Net/Shipping Weight (lbs)	40/46	40/46	40/46
ODU Net/Shipping Weight (lbs)	125/133	125/133	125/133
<b>Compressor</b>			
Compressor Type (Qty)	Twin Rotary (1)	Twin Rotary (1)	Twin Rotary (1)
<b>Fan</b>			
IDU Type (Qty)	Cross Flow		
ODU Type (Qty)	Propeller		
Motor/Drive	Brushless Digitally Controlled/Direct		
<b>Airflow Rate</b>			
IDU Max/H/M/L (CFM)	848/706/530/459	848/706/530/459	848/706/530/459
ODU Max (CFM)	2,119	2,119	2,119
<b>Piping</b>			
Liquid Line (in, OD)	3/8	3/8	3/8
Vapor Line (in, OD)	5/8	5/8	5/8
Condensation Line (OD, ID)	27/32, 5/8	27/32, 5/8	27/32, 5/8
Additional Refrigerant Charge (oz/ft)	0.38	0.38	0.38
Pipe Length <sup>5</sup> (ft) (Min./Max.)	9.8/164	9.8/164	9.8/164
Piping Length <sup>5</sup> (no add'l refrigerant, ft)	24.6	24.6	24.6
Max Elevation Difference (ft)	98.4	98.4	98.4

EEV: Electronic Expansion Valve IDU: Indoor Unit ODU: Outdoor Unit

<sup>1</sup>Power Input is rated at high speed.

<sup>2</sup>Take appropriate actions at the end of HVAC equipment life to recover, recycle, reclaim or destroy R410A refrigerant according to applicable regulations (40 CFR Part 82, Subpart F) under section 608 of CAA.

<sup>3</sup>Sound Pressure levels are tested in an anechoic chamber under ISO Standard 1996.

<sup>4</sup>Power/communication cables from the outdoor unit to the indoor unit to be minimum 18 AWG, 4-conductor, stranded, shielded or unshielded (if shielded, it must be grounded to the chassis at the outdoor unit only) and must comply with applicable and national code.

<sup>5</sup>Piping lengths are equivalent.

Power wiring to the outdoor unit is field supplied, solid or stranded, and must comply with the applicable local and national codes.

This unit comes with a dry helium charge.

This data is rated 0 ft above sea level with 24.6 of refrigerant line per indoor unit and a 0 ft level difference outdoor and indoor units.

Cooling capacity rating obtained with air entering the indoor unit at 80°F dry bulb (DB) and 67°F wet bulb (WB) and outdoor ambient conditions of 95°F dry bulb (DB) and 75°F wet bulb (WB). Heating capacity rating obtained with air entering the indoor unit at 70°F dry bulb (DB) and 59°F wet bulb (WB) and outdoor ambient conditions of 47°F dry bulb (DB) and 43°F wet bulb (WB).

# GENERAL DATA

## Single Zone Mega Unit (HEV) Specifications

Table 4: Single Zone Mega Unit (HEV) Specifications

Type System (Model IDU/ODU)	Single Zone Mega (HEV) Inverter			
	LS090HEV (LSN090HEV/ LSU090HEV)	LS120HEV (LSN120HEV/ LSU120HEV)	LS180HEV (LSN180HEV/ LSU180HEV)	LS240HEV (LSN240HEV/ LSU240HEV)
Nominal Cooling Capacity (Btu/h)	8,500	12,000	17,000	22,000
Cooling Power Input <sup>1</sup> (kW)	0.78	1.17	1.55	2.04
Nominal Heating Capacity (Btu/h)	9,000	12,000	19,000	22,000
Heating Power Input <sup>1</sup> (kW)	0.78	0.98	1.59	1.93
COP	3.19	3.00	3.19	3.00
EER	10.90	10.26	10.95	10.75
SEER	16.3	16.3	17.0	17.0
HSPF	8.3	8.5	8.7	8.5
Power Supply (V / Hz / Ø)	208-230/60/1			
<i>ODU Operating Range</i>				
Cooling (°F DB)	64-118			
Heating (°F WB)	23-75			
<i>IDU Operating Range</i>				
Cooling (°F WB)	64-90			
Heating (°F DB)	60-86			
<i>Indoor Temperature Setting Range</i>				
Cooling (°F)	65-86			
Heating (°F)	61-86			
<i>Unit Data</i>				
Refrigerant Type <sup>2</sup>	R410A			
Refrigerant Control	Capillary Tube			
IDU Sound Pressure <sup>3</sup> ± 3 dB(A) (H/M/L)	39/33/25	39/33/25	42/40/35	45/40/35
ODU Sound Pressure ± 3 dB(A)	47	47	51	53
Indoor Unit (Net/Shipping Weight lbs.)	16/21	20/25	28/30	28/34
Outdoor Unit (Net/Shipping Weight lbs.)	52/56	49/53	72/77	92/104
Power/Communication Cable <sup>4</sup> (No. x AWG)	4 x 18			
<i>Compressor</i>				
Compressor Type (Qty)	Single Rotary (1)	Single Rotary (1)	Twin Rotary (1)	Twin Rotary (1)
<i>Fan</i>				
Indoor Type (Qty)	Cross Flow (1)			
Outdoor Type (Qty)	Propeller (1)			
Motor/Drive	Brushless Digitally Controlled/Direct			
<i>Airflow Rate</i>				
Indoor - Max/H/M/L (CFM)	318/276/226/177	424/353/272/212	629/512/441/353	689/600/494/388
Outdoor - Max (CFM)	953	953	1,342	1,766
<i>Piping</i>				
Liquid Line (in, OD)	1/4	1/4	1/4	1/4
Vapor Line (in, OD)	3/8	3/8	1/2	5/8
Condensation Line (OD   ID)	27/32   5/8	27/32   5/8	27/32   5/8	27/32   5/8
Additional Refrigerant Charge (oz/ft)	0.22	0.22	0.33	0.33
Pipe Length <sup>5</sup> (ft) (Min./Max.)	9.8/49.2	9.8/49.2	9.8/65.6	9.8/65.6
Piping Length (no add'l refrigerant, ft) <sup>5</sup>	24.6	24.6	24.6	24.6
Max Elevation Difference (ft)	22.9	22.9	32.8	32.8

EEV: Electronic Expansion Valve IDU: Indoor Unit ODU: Outdoor Unit

<sup>1</sup>Power Input is rated at high speed.

<sup>2</sup>Take appropriate actions at the end of HVAC equipment life to recover, recycle, reclaim or destroy R410A refrigerant according to applicable regulations (40 CFR Part 82, Subpart F) under section 608 of CAA.

<sup>3</sup>Sound Pressure levels are tested in an anechoic chamber under ISO Standard 1996.

<sup>4</sup>Power/communication cables from the outdoor unit to the indoor unit to be minimum 18 AWG, 4-conductor, stranded, shielded or unshielded (if shielded, it must be grounded to the chassis at the outdoor unit only) and must comply with applicable and national code.

<sup>5</sup>Piping lengths are equivalent.

Power wiring to the outdoor unit is field supplied, solid or stranded, and must comply with the applicable local and national codes. This unit comes with a dry helium charge.

This data is rated 0 ft above sea level with 24.6 of refrigerant line per indoor unit and a 0 ft level difference outdoor and indoor units.

Cooling capacity rating obtained with air entering the indoor unit at 80°F dry bulb (DB) and 67°F wet bulb (WB) and outdoor ambient conditions of 95°F dry bulb (DB) and 75°F wet bulb (WB).

Heating capacity rating obtained with air entering the indoor unit at 70°F dry bulb (DB) and 59°F wet bulb (WB) and outdoor ambient conditions of 47°F dry bulb (DB) and 43°F wet bulb (WB).

# GENERAL DATA

## Single Zone Mega Unit (HEV1) Specifications

Table 5: Single Zone Mega Unit (HEV1) Specifications

Type System (Model IDU/ODU)	Single Zone Mega (HEV1) Inverter			
	LS090HEV1 (LSN090HEV1/ LSU090HEV1)	LS120HEV1 (LSN120HEV1/ LSU120HEV1)	LS180HEV1 (LSN180HEV1/ LSU180HEV1)	LS240HEV1 (LSN240HEV1/ LSU240HEV1)
Nominal Cooling Capacity (Btu/h)	8,500	12,000	17,000	22,000
Cooling Power Input <sup>1</sup> (kW)	0.68	1.14	1.55	2.045
Nominal Heating Capacity (Btu/h)	9,000	12,000	19,000	22,000
Heating Power Input <sup>1</sup> (kW)	0.78	0.98	1.59	1.935
COP	11.54	12.24	11.95	11.37
EER	12.5	10.52	10.97	10.76
SEER	19.0	17.0	18.0	17.0
HSPF	9.0	9.2	9.0	9.0
Power Supply (V / Hz / Ø)	208-230/60/1			
<i>ODU Operating Range</i>				
Cooling (°F DB)	14-118			
Heating (°F WB)	14-65			
<i>IDU Operating Range</i>				
Cooling (°F WB)	53-75			
Heating (°F DB)	60-86			
<i>Indoor Temperature Setting Range</i>				
Cooling (°F)	64-86			
Heating (°F)	60-86			
<i>Unit Data</i>				
Refrigerant Type <sup>2</sup>	R410A			
Refrigerant Control	EEV			
IDU Sound Pressure <sup>3</sup> ± 3 dB(A) (H/M/L)	39/33/25/19	39/33/25/19	42/40/35/29	45/40/35/29
ODU Sound Pressure ± 3 dB(A)	47	47	51	53
Indoor Unit (Net/Shipping Weight lbs.)	17/20	23/28	28/33	28/44
Outdoor Unit (Net/Shipping Weight lbs.)	62/67	62/67	76/81	95/104
Power/Communication Cable <sup>4</sup> (No. x AWG)	4 x 18			
<i>Compressor</i>				
Compressor Type (Qty)	Single Rotary (1)	Single Rotary (1)	Twin Rotary (1)	Twin Rotary (1)
<i>Fan</i>				
Indoor Type (Qty)	Cross Flow (1)			
Outdoor Type (Qty)	Propeller (1)			
Motor/Drive	Brushless Digital Controlled/Direct			
<i>Airflow Rate</i>				
Indoor - Max/H/M/L (CFM)	318/276/226/177	424/353/272/212	629/512/441/353	689/600/494/388
Outdoor - Max (CFM)	953	953	1,342	1,766
<i>Piping</i>				
Liquid Line (in, OD)	1/4	1/4	1/4	1/4
Vapor Line (in, OD)	3/8	3/8	1/2	5/8
Condensation Line (OD   ID)	27/32, 5/8	27/32, 5/8	27/32, 5/8	27/32, 5/8
Additional Refrigerant Charge (oz/ft)	0.22	0.22	0.33	0.33
Pipe Length <sup>5</sup> (ft) (Min./Max.)	9.8/49.2	9.8/49.2	9.8/65.6	9.8/65.6
Piping Length (no add'l refrigerant, ft) <sup>5</sup>	24.6	24.6	24.6	24.6
Max Elevation Difference (ft)	22.9	22.9	32.8	32.8

EEV: Electronic Expansion Valve IDU: Indoor Unit ODU: Outdoor Unit

<sup>1</sup>Power Input is rated at high speed.

<sup>2</sup>Take appropriate actions at the end of HVAC equipment life to recover, recycle, reclaim or destroy R410A refrigerant according to applicable regulations (40 CFR Part 82, Subpart F) under section 608 of CAA.

<sup>3</sup>Sound Pressure levels are tested in an anechoic chamber under ISO Standard 1996.

<sup>4</sup>Power/communication cables from the outdoor unit to the indoor unit to be minimum 18 AWG, 4-conductor, stranded, shielded or unshielded (if shielded, it must be grounded to the chassis at the outdoor unit only) and must comply with applicable and national code.

<sup>5</sup>Piping lengths are equivalent.

Power wiring to the outdoor unit is field supplied, solid or stranded, and must comply with the applicable local and national codes.

This unit comes with a dry helium charge.

This data is rated 0 ft above sea level with 24.6 of refrigerant line per indoor unit and a 0 ft level difference outdoor and indoor units.

Cooling capacity rating obtained with air entering the indoor unit at 80°F dry bulb (DB) and 67°F wet bulb (WB) and outdoor ambient conditions of 95°F dry bulb (DB) and 75°F wet bulb (WB). Heating capacity rating obtained with air entering the indoor unit at 70°F dry bulb (DB) and 59°F wet bulb (WB) and outdoor ambient conditions of 47°F dry bulb (DB) and 43°F wet bulb (WB).



# GENERAL DATA

## Single Zone Mega115V Unit Specifications

Table 6: Single Zone Mega 115V Unit Specifications

Type	Single Zone Mega Inverter	
System (Model IDU/ODU)	LS090HXV (LSN090HXV/LSU090HXV)	LS120HXV (LSN120HXV/LSU120HXV)
Nominal Cooling Capacity (Btu/h)	8,500	12,000
Cooling Power Input <sup>1</sup> (kW)	0.71	1.14
Nominal Heating Capacity (Btu/h)	10,900	13,000
Heating Power Input <sup>1</sup> (kW)	0.88	1.09
COP	3.63	3.50
EER	12.01	10.5
SEER	17.0	17.0
HSPF	9.0	9.0
Power Supply (V / Hz / Ø)	115/60/1	
<i>ODU Operating Range</i>		
Cooling (°F DB)	14-118	
Heating (°F WB)	14-75	
<i>IDU Operating Range</i>		
Cooling (°F WB)	64-90	
Heating (°F DB)	60-86	
<i>Indoor Temperature Setting Range</i>		
Cooling (°F)	65-86	
Heating (°F)	61-86	
<i>Unit Data</i>		
Refrigerant Type <sup>2</sup>	R410A	
Refrigerant Control	EEV	
IDU Sound Pressure <sup>3</sup> ± 3 dB(A) (H/M/L)	39/33/25	39/33/25
ODU Sound Pressure ± 3 dB(A)	47	47
Indoor Unit (Net/Shipping Weight lbs.)	23/26	23/26
Outdoor Unit (Net/Shipping Weight lbs.)	67/79	67/79
Power/Communication Cable <sup>4</sup> (No. x AWG)	4 x 18	
<i>Compressor</i>		
Compressor Type (Qty)	Single Rotary (1)	Single Rotary (1)
<i>Fan</i>		
Indoor Type (Qty)	Cross Flow (1)	
Outdoor Type (Qty)	Propeller (1)	
Motor/Drive	Brushless Digitally Controlled/Direct	
<i>Airflow Rate</i>		
Indoor - Max/H/M/L (CFM)	335/272/212/124	335/272/212/124
Outdoor - Max (CFM)	1,000	1,000
<i>Piping</i>		
Liquid Line (in, OD)	1/4	1/4
Vapor Line (in, OD)	3/8	3/8
Condensation Line (OD   ID)	27/32   5/8	27/32   5/8
Additional Refrigerant Charge (oz/ft)	0.22	0.22
Pipe Length <sup>5</sup> (ft) (Min./Max.)	6.6/49.2	6.6/49.2
Piping Length (no add'l refrigerant, ft) <sup>5</sup>	24.6	24.6
Max Elevation Difference (ft)	23	23

EEV: Electronic Expansion Valve IDU: Indoor Unit ODU: Outdoor Unit

<sup>1</sup>Power Input is rated at high speed.

<sup>2</sup>Take appropriate actions at the end of HVAC equipment life to recover, recycle, reclaim or destroy R410A refrigerant according to applicable regulations (40 CFR Part 82, Subpart F) under section 608 of CAA.

<sup>3</sup>Sound Pressure levels are tested in an anechoic chamber under ISO Standard 1996.

<sup>4</sup>Power/communication cables from the outdoor unit to the indoor unit to be minimum 18 AWG, 4-conductor, stranded, shielded or unshielded (if shielded, it must be grounded to the chassis at the outdoor unit only) and must comply with applicable and national code.

<sup>5</sup>Piping lengths are equivalent.

Power wiring to the outdoor unit is field supplied, solid or stranded, and must comply with the applicable local and national codes.

This unit comes with a dry helium charge.

This data is rated 0 ft above sea level with 24.6 of refrigerant line per indoor unit and a 0 ft level difference outdoor and indoor units.

Cooling capacity rating obtained with air entering the indoor unit at 80°F dry bulb (DB) and 67°F wet bulb (WB) and outdoor ambient conditions of 95°F dry bulb (DB) and 75°F wet bulb (WB).

Heating capacity rating obtained with air entering the indoor unit at 70°F dry bulb (DB) and 59°F wet bulb (WB) and outdoor ambient conditions of 47°F dry bulb (DB) and 43°F wet bulb (WB).

# GENERAL DATA

## Electrical

Table 7: Single Zone High Efficiency Indoor Unit Electrical Data

Model Number	Nom. Tons	Compressor Qty	Compressor (A) Cool/Heat	Fan Qty	ODU Fan (A)	IDU Fan (A)	MCA (A)	MOP (A)
LSU091HSV3	3/4	1	8.7/8.7	1	0.40	0.4	10	15
LSU121HSV3	1	1	8.7/8.7	1	0.40	0.4	10	15
LSU181HSV3	1-1/2	1	15.4/15.4	1	0.25	0.4	19	25
LSU240HSV3	1-3/4	1	15.4/15.4	1	0.25	0.5	19	25

Table 8: Single Zone Standard Indoor Unit Electrical Data

Model Number	Nom. Tons	Compressor Qty	Compressor (A) Cool/Heat	Fan Qty	ODU Fan (A)	IDU Fan (A)	MCA (A)	MOP (A)
LSU307HV3	2-1/2	1	15.4/15.4	1	0.25	0.5	19	25
LSU360HV3	2-3/4	1	15.4/15.4	1	0.25	0.5	19	25

Table 9: Single Zone Extended Pipe Indoor Unit Electrical Data

Model Number	Nom. Tons	Compressor Qty	Compressor (A) Cool/Heat	Fan Qty	ODU Fan (A)	IDU Fan (A)	MCA (A)	MOP (A)
LSU240HLV	1-3/4	1	17.3/17.3	1	0.25	0.5	23	35
LSU300HLV	2-1/2	1	17.3/17.3	1	0.25	0.5	23	35
LSU360HLV	2-3/4	1	17.3/17.3	1	0.25	0.5	23	35

Table 10: 208-230V, 60Hz, 1-Phase Single Zone Mega (HEV) Indoor Unit Electrical Data

Unit Model Nos.	Nom. Tons	Compressor Qty	Compressor (A) Cool/Heat	Fan Qty	ODU Fan (A)	IDU Fan (A)	MCA (A)	MOP (A)
LSU090HEV	3/4	1	6.8/6.8	1	0.5	0.5	9	15
LSU120HEV	1	1	6.8/6.8	1	0.5	0.5	9	15
LSU180HEV	1-1/2	1	8.68/9.28	1	0.4	0.4	12	20
LSU240HEV	2	1	10.8/9.6	1	0.48	0.48	14	20

Table 11: 208-230V, 60Hz, 1-Phase Single Zone Mega (HEV1) Indoor Unit Electrical Data

Unit Model Nos.	Nom. Tons	Compressor Qty	Compressor (A) Cool/Heat	Fan Qty	ODU Fan (A)	IDU Fan (A)	MCA (A)	MOP (A)
LSU090HEV1	3/4	1	7.0/7.0	1	0.5	0.5	10	15
LSU120HEV1	1	1	7.0/7.0	1	0.5	0.5	10	15
LSU180HEV1	1-1/2	1	8.81/8.61	1	0.4	0.4	12	20
LSU240HEV1	2	1	10.72/10.28	1	0.4	0.4	15	20

Table 12: 115V, 60Hz, 1-Phase Single Zone Mega 115V Indoor Unit Electrical Data

Unit Model Nos.	Nom. Tons	Compressor Qty	Compressor (A) Cool/Heat	Fan Qty	ODU Fan (A)	IDU Fan (A)	MCA (A)	MOP (A)
LSU090HXV	3/4	1	10/10	1	0.4	0.5	13.5	20
LSU120HXV	1	1	10/10	1	0.4	0.5	13.5	20

Voltage tolerance is  $\pm 10\%$ .

Maximum allowable voltage unbalance is 2%.

MSC = Maximum Starting Current.

MCA = Minimum Circuit Ampacity.

Maximum Overcurrent Protection (MOP) is calculated as follows: (Largest motor FLA x 2.25) + (Sum of other motor FLA) rounded down to the nearest standard fuse size.

# GENERAL DATA

## R410A Refrigerant

---

---

### R410A Refrigerant

R410A refrigerant has a higher operating pressure in comparison to R22 refrigerant and, therefore, all piping system materials installed must have a higher resisting pressure than the materials traditionally used in R22 systems.

R410A refrigerant is an azeotrope of R32 and R125, mixed at 50:50, so the ozone depletion potential (ODP) is 0. Many countries have approved of and encouraged R410A for use as an alternate refrigerant.

#### **DANGER**

 Do not use any piping that has not been approved for use in high-pressure refrigerant systems. There is risk of fire, explosion and physical injury or death. Improper piping may also cause refrigerant leaks. If the refrigerant leaks and safety limits are exceeded, it could result in personal injuries or death from oxygen depletion.

#### **WARNING**

 Do not place the refrigerant cylinder in direct sunlight. There is risk of fire, explosion, and physical injury or death.

#### **Note:**

-  Do not use any piping that has not been approved for use in high-pressure refrigerant systems. Improper piping may cause refrigerant leaks and system malfunction.
- Piping wall thickness must comply with the applicable local, state, and federal codes for the 551 psi design pressure of R410A.
- Because R410A is a combination of R32 and R125, the required additional refrigerant must be charged in its liquid state. If the refrigerant is charged in its gaseous state, its composition changes and the system will not work properly.



# GENERAL INSTALLATION GUIDELINES

## Location Selection

---

---

### Selecting the Best Location

#### **⚠ DANGER**

- To avoid the possibility of fire, Ⓞ do not install the unit in an area where combustible gas may generate, flow, stagnate, or leak.
- Ⓞ Do not install the unit in a location where acidic solution and spray (sulfur) are often used as it can cause bodily injury or death.
- Ⓞ Do not use the unit in environments where oil, steam, or sulfuric gas are present as it can cause bodily injury or death.

#### **⚠ WARNING**

Install a fence to prevent vermin from crawling into the unit or unauthorized individuals from accessing it.

#### **Note:**

Select a location for installing the outdoor unit that will meet the following conditions:

- Where the unit will not be subjected to direct thermal radiation from other heat sources.
- Where operating sound from the unit will not disturb inhabitants of surrounding buildings.
- Where the unit will not be exposed to direct, strong winds.
- Where there is enough strength to bear the weight of the unit.
- Include space for drainage to ensure condensate flows properly out of the unit when it is in heating mode.
- Include enough space for air flow and for service access.

#### **Note:**

To ensure the outdoor unit operates properly, certain measures are required in locations where there is a possibility of heavy snowfall or severe wind-chill or cold:

1. Prepare for severe winter wind chills and heavy snowfall, even in areas of the country where these are unusual phenomena.
2. Position the outdoor unit so that its airflow fans are not buried by direct, heavy snowfall. If snow piles up and blocks the airflow, the system may malfunction.
3. Remove any snow that has accumulated 3-15/16 inches or more on the top of the outdoor unit.
4. Place the outdoor unit on a raised platform at least 19-11/16 inches higher than the average annual snowfall for the area. In environments where there is a possibility of heavy snow, the frame height must be more than two (2) times the amount of average annual snowfall, and should not exceed the width of the outdoor unit. If the frame width is wider than the outdoor unit, snow may accumulate.
5. Install a snow protection hood.
6. To prevent snow and heavy rain from entering the outdoor unit, install the suction and discharge ducts facing away from direct winds.
7. Additionally, the following conditions should be taken into consideration when the unit operates in defrost mode:
  - If the outdoor unit is installed in a highly humid environment (near an ocean, lake, etc.), ensure that the site is well-ventilated and has a lot of natural light. (Example: Install on a rooftop.)
  - Sidewalks or parking lots near the outdoor unit may accumulate moisture after unit operates in defrost mode that can turn to ice.

#### **Note:**

The indoor unit may take longer to provide heat, or heating performance will be reduced in winter if the unit is installed:

1. In a narrow, shady location.
2. Near a location that has a lot of ground moisture.
3. In a highly humid environment.
4. In an area in which condensate does not drain properly.

### Ambient Air Conditions

#### **Note:**

- Avoid exposing the outdoor unit to steam, combustible gases, or other corrosive elements.
- Avoid exposing the unit to discharge from boiler stacks, chimneys, steam relief ports, other air conditioning units, kitchen vents, plumbing vents, or substances that may degrade performance or cause damage to the unit.
- When installing multiple outdoor units, avoid placing the units where discharge of one outdoor unit will blow into the inlet side of an adjacent unit.

#### **⚠ WARNING**

Avoid exposing the unit to sources of extreme temperature or gases to prevent serious bodily injury.

# GENERAL INSTALLATION GUIDELINES

## Oceanside Applications

### Oceanside Applications

#### Use of a Windbreak to Shield from Sea Wind

**Note:**

Ocean winds may cause corrosion, particularly on the condenser and evaporator fins, which, in turn could cause product malfunction or inefficient performance.

- Avoid installing the outdoor unit where it would be directly exposed to ocean winds.
- Install the outdoor unit on the side of the building opposite from direct ocean winds.
- Select a location with good drainage.
- Periodically clean dust or salt particles off of the heat exchanger with water.
- If the outdoor unit must be placed in a location where it would be subjected to direct ocean winds, install a concrete windbreak strong enough to block any winds.
- Windbreak should be more than 150% of the outdoor unit's height. There must be 2 to 3-1/2 inches of clearance between the outdoor unit and the windbreaker for purposes of air flow.

#### Use of a Building to Shield from Sea Wind

If a windbreak is not possible, a building or larger structure must be used to shield the outdoor unit from direct exposure to the sea wind. The unit should be placed on the side of the building directly opposite to the direction of the wind as shown in Figure 2.

Figure 1: Oceanside Placement Using Windbreak

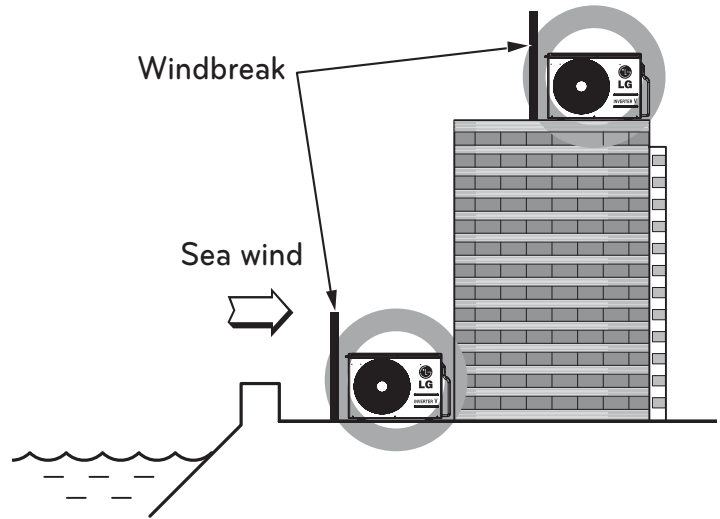

**Note:**

Additional anti-corrosion treatment may need to be applied to the outdoor unit at oceanside locations.

Figure 2: Placement Using Building as Shield

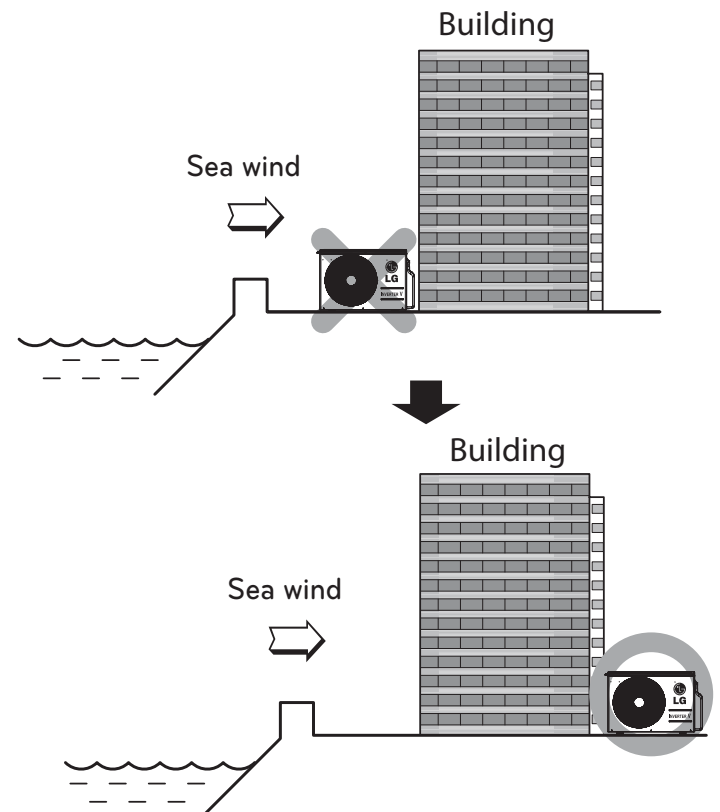

# GENERAL INSTALLATION GUIDELINES

## Mounting Bolt Location

### General Mounting

Securely attach the outdoor unit to a condenser pad, base rails, or another mounting platform that is securely anchored to the ground or building structure. Attach the outdoor unit with a bolt and nut on a concrete or rigid mount. See Figure 3. Follow applicable local codes for clearance, mounting, anchor and vibration attenuation requirements.

**Note:**

All referenced materials are to be field-supplied. Images are not to scale.

### Mounting Platform

The underlying structure or foundation must be designed to support the weight of the unit. Avoid placing the unit in a low lying area where water may accumulate. When installing the outdoor unit on the wall or roof top, anchor the mounting base securely to account for wind, earthquakes or vibration.

Figure 3: Outdoor Unit Mounting Methods

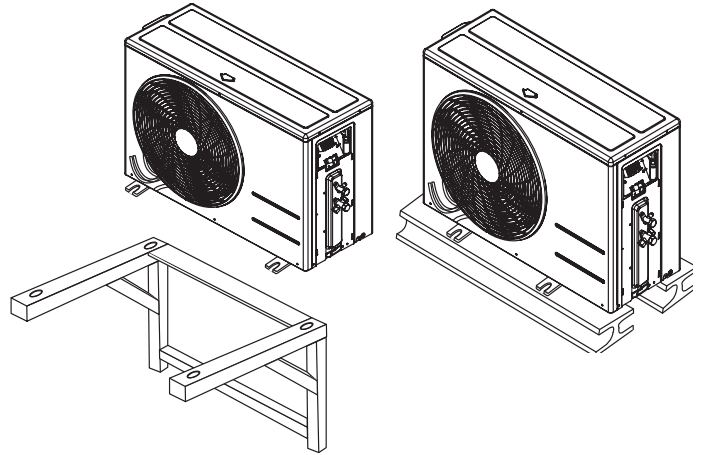

### Tie-Downs and Wind Restraints

The strength of the Single Zone system frame is adequate to be used with field-provided wind restraint tie-downs. The overall tie-down configuration must be approved by a local professional engineer.

**Note:**

Always refer to local code when designing a wind restraint system.

### Snow and Ice Conditions

In climates that experience snow build-up, place the unit on a raised platform to ensure condenser airflow. The raised support platform must be high enough to allow the unit to remain above possible snow drifts. Mount the unit on a field-provided snow stand at a minimum height that is equal to the average annual snowfall plus 20 inches. Design the mounting base to prevent snow accumulation on the platform in front or back of the unit case. If necessary, provide a field fabricated hood to keep snow and ice and/or drifting snow from accumulating on the coil surfaces. Use inlet and discharge duct or hoods to prevent snow or rain from accumulating on the fan inlet and outlet guards. Best practice prevents snow from accumulating on top of the unit. Consider tie-down requirements in case of high winds or where required by local codes.

### CAUTION

When deciding on a location to place the outdoor unit, be sure to choose an area where run-off from defrost will not accumulate and freeze on sidewalks or driveways which may create unsafe conditions.

Proper airflow through the Single Zone outdoor unit coil is critical for correct unit operation. When installing, consider service, inlet and outlet, and minimum allowable space requirements as illustrated in the diagrams to follow.

### Minimum Clearance Requirements for Single Zone Systems

#### Outdoor Unit Clearance

Specific clearance requirements in the diagrams on the next page are for the single zone wall mount systems. Figure 4 shows the overall minimum clearances that must be observed for safe operation and adequate airflow around the outdoor unit.

When placing the outdoor unit under an overhang, awning, sunroof or other “roof-like structure, observe the clearance requirements (as shown in Figure 5) for height in relation to the unit. This clearance ensures that heat radiation from the condenser is not restricted around the unit. See Figures 6 and 7 for recommendations when other obstacles are present.

Adhere to all clearance requirements if installing the unit on a roof. Be sure to level the unit and ensure that the unit is adequately anchored. Consult local codes for rooftop mounting requirements.

# GENERAL INSTALLATION GUIDELINES

## Required Clearances

Figure 4: Outdoor Unit Clearances

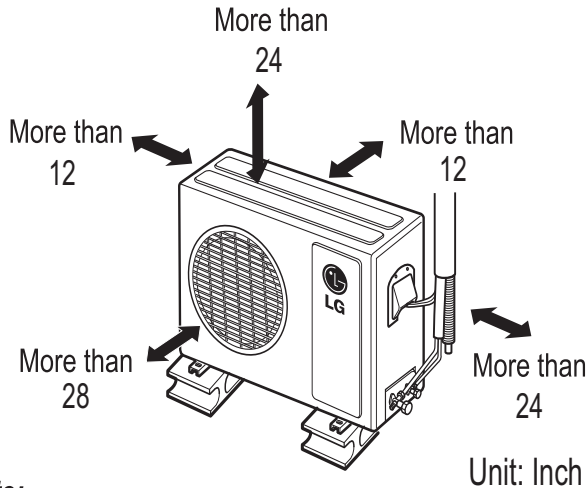
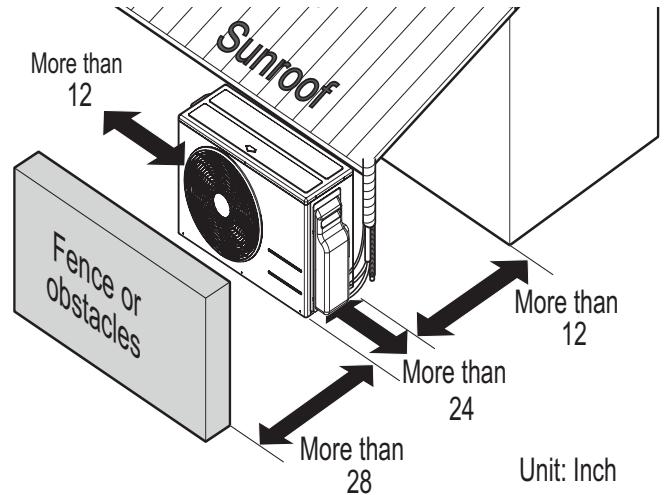

Figure 5: Outdoor Unit Sunroof/Awning Clearances



**Note:**

⊘ Do not place the unit where animals and/or plants will be in the path of the warm air, or where the warm air and/or noise will disturb neighbors.

Figure 6: Clearances Where There Are Obstacles on Both Air Inlet and Outlet Sides (Obstacle on the Outlet Side is Lower Than the Outdoor Unit)

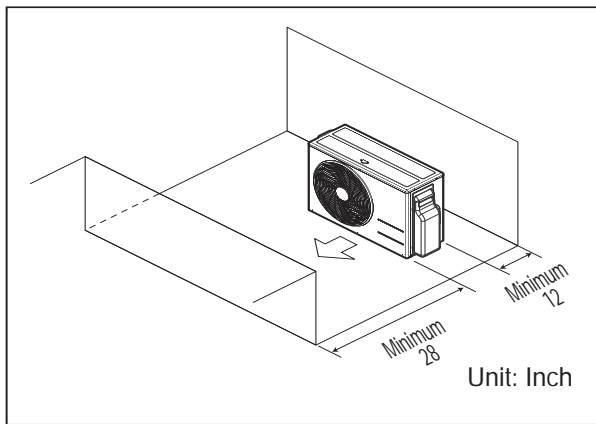
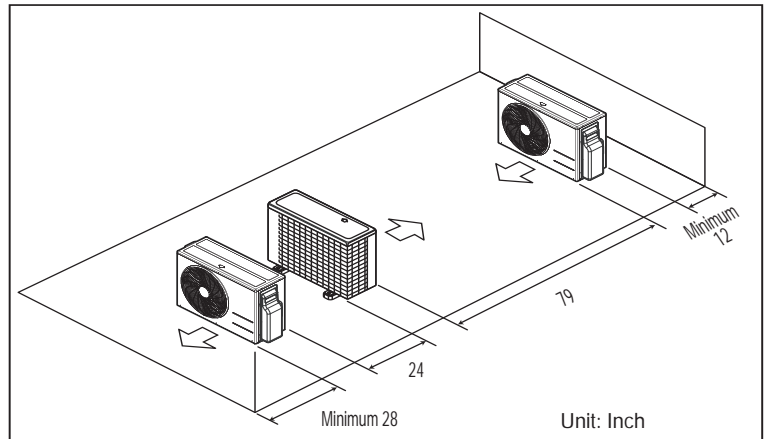

Figure 7: Clearances Where There are Obstacles Above and on Both Air Inlet and Outlet Sides (Obstacle on the Outlet Side is Lower Than the Outdoor Unit)



**Indoor Unit Clearance**

Follow recommended best practices when choosing an indoor location for the Single Zone Wall-Mounted indoor unit.

- Keep unit away from any indoor steam or excessive heat.
- ⊘ No obstacles should be placed around unit.
- Condensation drain (leakage piping) should be routed away from the unit.
- ⊘ Do not install near a doorway.
- Clearance gap between any wall or enclosure and the left or right side of the unit must be greater than 4 inches.
- From the top of the unit to the ceiling there must be greater than 5 or 8 inches of clearance (depending on indoor unit model).
- Unit should be at least 6.5 feet from the floor for adequate clearance.

Figure 8: Single Zone Indoor Unit Clearance Requirements

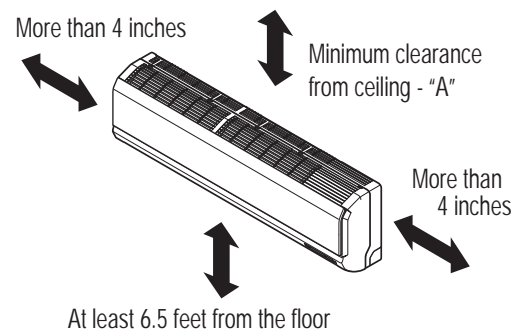

Table 13: Indoor Unit Ceiling Clearance

"A" Ceiling Clearance (inches)	Indoor Unit Model(s)
5	LSN090-120HEV1, LSN091~121HSV3
8	LSN181~240HSV3, LS307-360HV3, LSN240~360HLV, LSN90~240HEV, LSN180-240HEV1, LSN090-120HXV

Due to our policy of continuous product innovation, some specifications may change without notification.  
 ©LG Electronics U.S.A., Inc., Englewood Cliffs, NJ. All rights reserved. "LG" is a registered trademark of LG Corp.

# GENERAL INSTALLATION GUIDELINES

## Mounting of Indoor Unit Installation Plate

### Mounting Installation Plate to Wall (091HSV3, 121HSV3, 181HSV3)

Follow the procedure and best practices below when mounting the Wall-Mounted indoor unit's plate to a wall.

#### Procedure

1. Before installation of the plate, confirm the position the screw types (A or B) between chassis and installation plate.
2. Mount the installation plate horizontally by aligning the centerline using a leveling tool.
3. Use provided screws when mounting the plating.
  - If mounting the unit on concrete wall, use field supplied anchor bolts.
4. Choose what side (left or right) to install the piping, and then observe the left and right rear piping clearances when drilling into the wall, as shown in Figures 9, 11, 12.

#### Note:

Select location carefully. Unit should be anchored to a strong wall to prevent unnecessary vibration.

#### ⚠ WARNING

- When choosing a location for the wall mount plate, be sure to take into consideration routing of wiring for power outlets within the wall. Contacting wiring can cause serious bodily injury, or death.
- Use caution when drilling holes through the walls for the purposes of piping connections. Power wiring can cause serious bodily injury, or death.

Refer to "Drilling Piping Hole in the Wall" on page 22 as you follow procedure to install the plate.

Figure 9: Installation Plate Screws - 091HSV3, 121HSV3

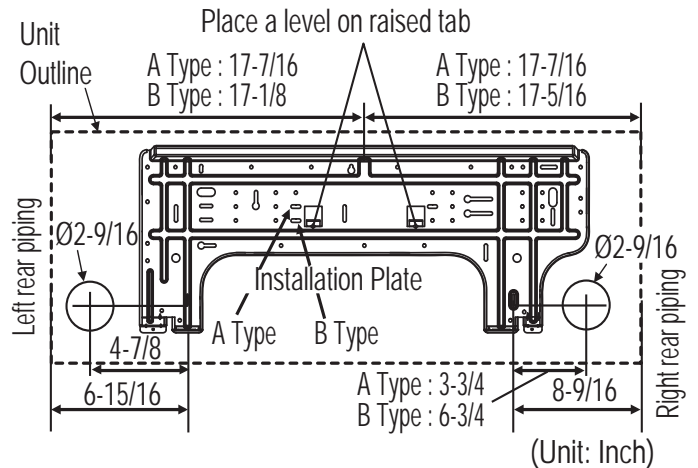

Figure 10: Installation Plate Screws

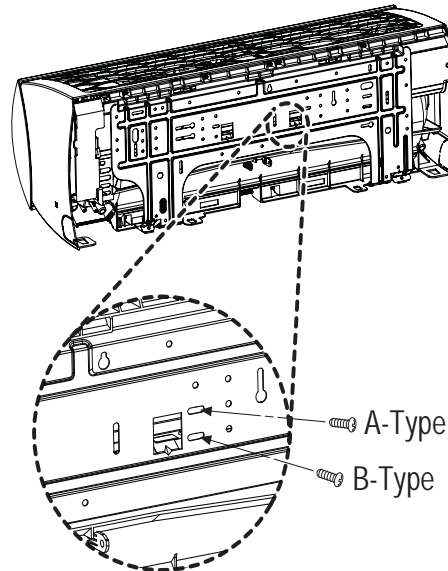

Figure 11: Installation Plate - 091HSV3, 121HSV3

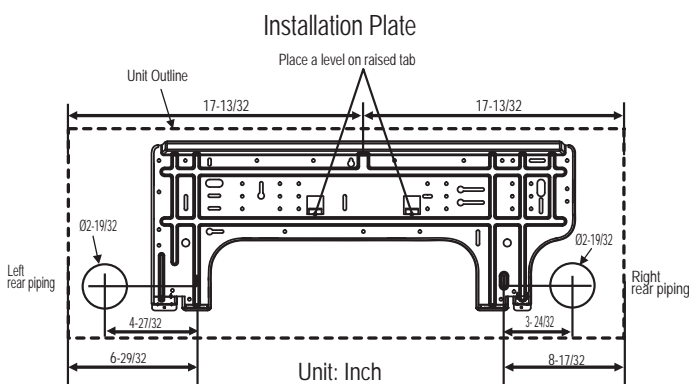
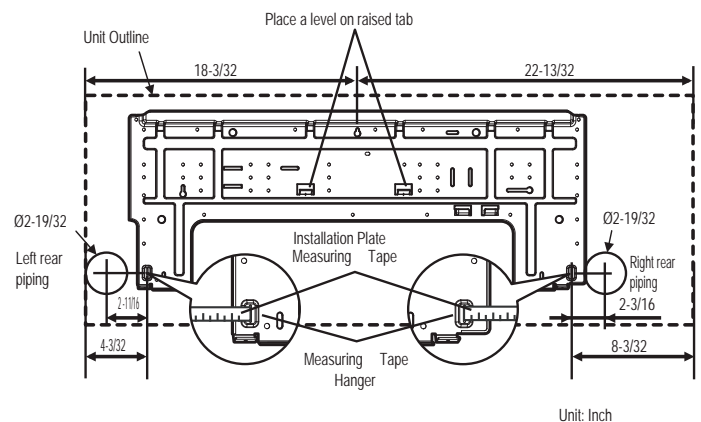

Figure 12: Installation Plate - 181HSV3



# GENERAL INSTALLATION GUIDELINES

## Mounting of Indoor Unit Installation Plate

### Mounting Installation Plate to Wall (240HSV3, HV3, HLV)

Follow the procedure and best practices when mounting the indoor unit's plate to a wall.

#### Procedure

1. Mount the installation plate horizontally by aligning the centerline using a leveling tool (Figure 13).
2. Use type "A" screws when mounting the plating (these screws come with the plate).
  - If mounting the unit on concrete wall, use field supplied anchor bolts.
3. Observe the left and right rear piping clearance when drilling into the wall, as shown in Figure 14.

#### Note:

Select location carefully. Unit should be anchored to a strong wall to prevent unnecessary vibration.

#### ⚠ WARNING

- When choosing a location for the wall mount plate, be sure to take into consideration routing of wiring for power outlets within the wall. Contacting wiring can cause serious bodily injury, or death.
- Use caution when drilling holes through the walls for the purposes of piping connections. Power wiring can cause serious bodily injury, or death.

### Drilling Piping Hole in the Wall

Follow the left or right piping clearance recommendations.

1. Using a 2-5/8 (Ø 65mm) inch hole core drill bit, drill a hole at either the right or left side of the wall mounting (Figure 15).
- The slant of the hole should be 3/16" to 5/16" from level with the slant being upward on the indoor unit side and downward on the outdoor unit side.
2. Finish off the newly drilled hole as shown with bushing and sleeve covering.
- Sleeve and bushing prevents damage to the tubing/bundling of the piping.

See *Refrigerant Piping Connections for Indoor Unit* on page 43 to proceed with piping.

Figure 13: Installation Plate - Mounting

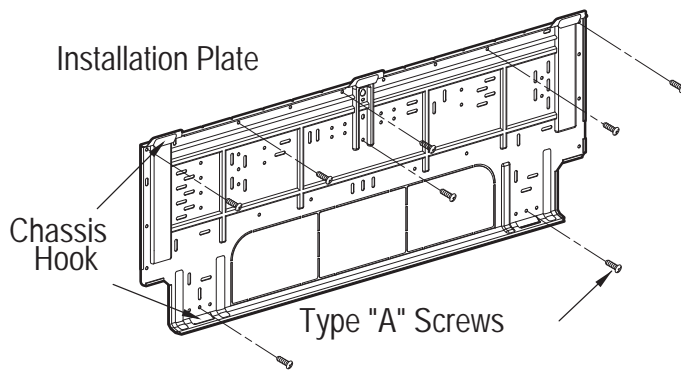

Figure 14: Installation Plate - Mounting

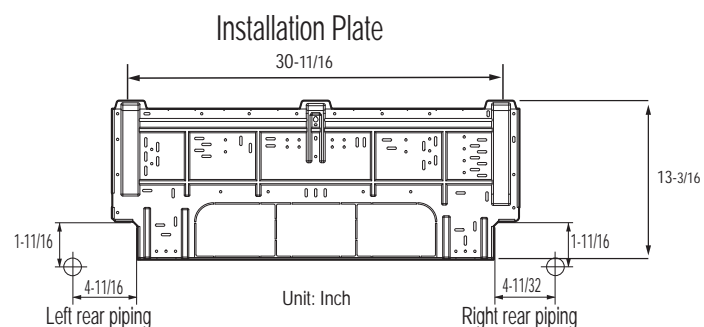
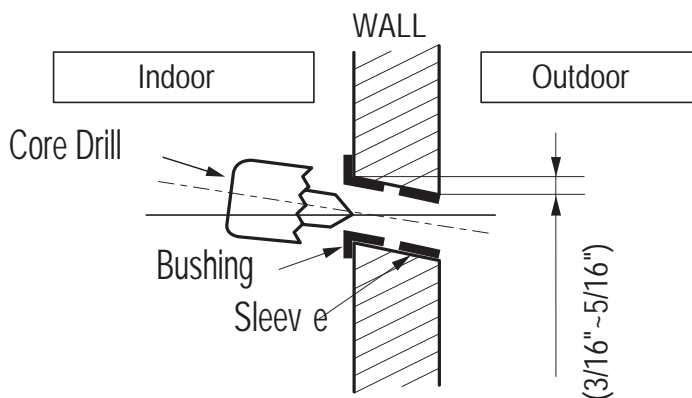

Figure 15: Drilling Piping Hole



# GENERAL INSTALLATION GUIDELINES

## Mounting of Indoor Unit Installation Plate

### Mounting Installation Plate to Wall (Mega 090HEV, 090HEV1, 120HEV, 120HEV1)

1. Confirm the position of screws between chassis and installation plate (Figure 16 and Figure 17).
2. Mount the installation plate horizontally by aligning the centerline using a leveling tool (Figure 18 and Figure 19).
3. Use provided screws when mounting the plating.
  - If mounting the unit on concrete wall, use field supplied anchor bolts.
4. Observe the left and right rear piping clearance when drilling into the wall as shown in Figure 18 (090HEV) and Figure 19 (120HEV).

**Note:**

Select location carefully. Unit should be anchored to a strong wall to prevent unnecessary vibration.

**⚠ WARNING**

- When choosing a location for the wall mount plate, be sure to take into consideration routing of wiring for power outlets within the wall. Contacting wiring can cause serious bodily injury, or death.
- Use caution when drilling holes through the walls for the purposes of piping connections. Power wiring can cause serious bodily injury, or death.

Refer to "Drilling Piping Hole in the Wall" on page 22 as you follow procedure to install plate.

Figure 16: Installation Plate Screw Type A - 090HEV, 090HEV1, 120HEV, 120HEV1

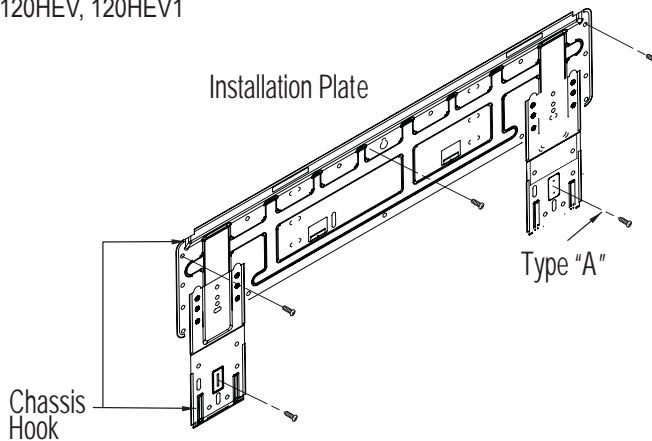

Figure 17: Installation Plate Screws Type A, Type B - 120HEV, 120HEV1

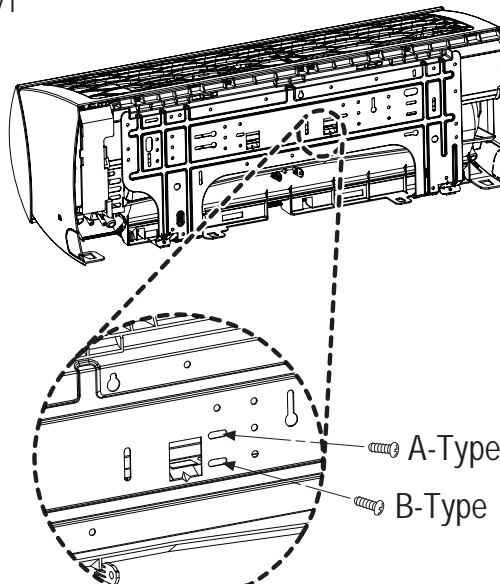

Figure 18: Installation Plate - 090HEV and 090HEV1

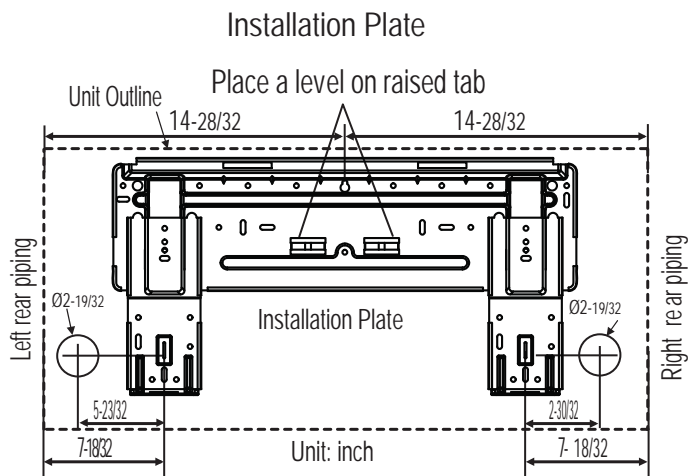
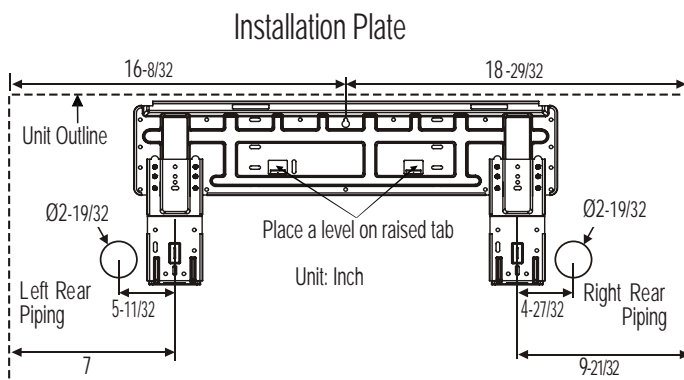

Figure 19: Installation Plate - 120HEV and 120HEV1



# GENERAL INSTALLATION GUIDELINES

## Mounting of Indoor Unit Installation Plate

### Mounting Installation Plate to Wall (Mega 180HEV, 180HEV1, 240HEV, 240HEV1)

1. Confirm the position of screws between chassis and installation plate (Figures 20 and 23).
2. Mount the installation plate horizontally by aligning the centerline using a leveling tool (Figures 21 and 22).
3. Use provided screws when mounting the plating.
  - If mounting the unit on concrete wall, use field supplied anchor bolts.
4. Observe the left and right rear piping clearance when drilling into the wall, as shown in Figures 21 and 22.

**Note:**

Select location carefully. Unit should be anchored to a strong wall to prevent unnecessary vibration.

**⚠ WARNING**

- When choosing a location for the wall mount plate, be sure to take into consideration routing of wiring for power outlets within the wall. Contacting wiring can cause serious bodily injury, or death.
- Use caution when drilling holes through the walls for the purposes of piping connections. Power wiring can cause serious bodily injury, or death.

Refer to "Drilling Piping Hole in the Wall" on page 22 as you follow procedure to install plate.

Figure 20: Installation Plate Showing Screw Locations - 180HEV, 240HEV

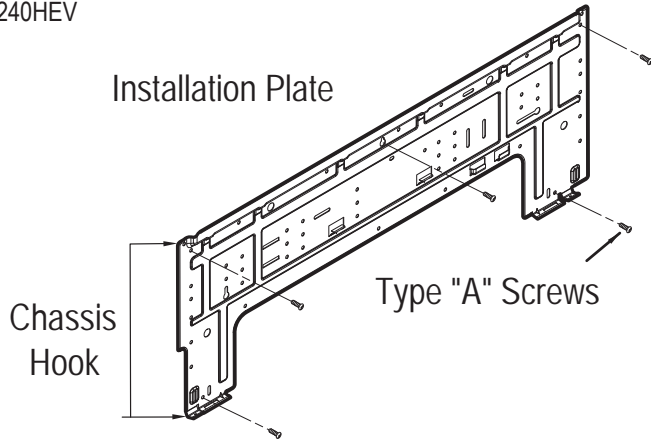

Figure 23: Installation Plate Showing Screw Locations - 180HEV1, 240HEV1

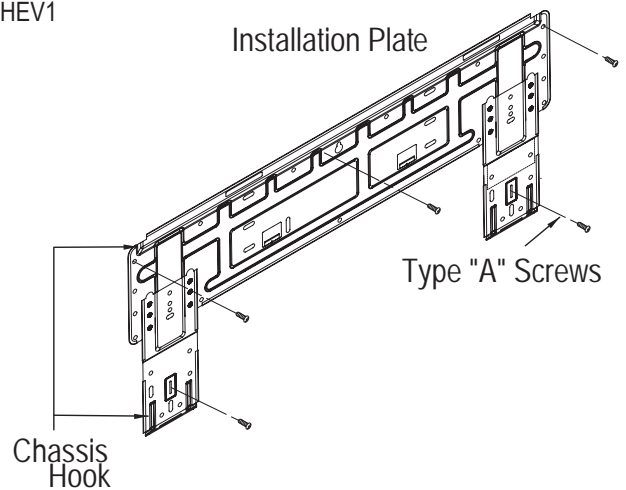

Figure 21: Installation Plate - 180HEV, 240HEV

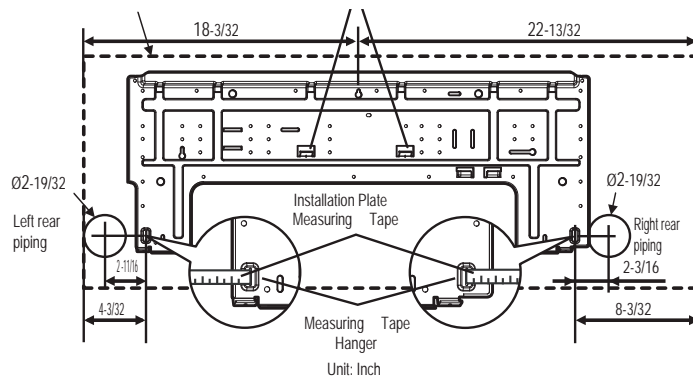
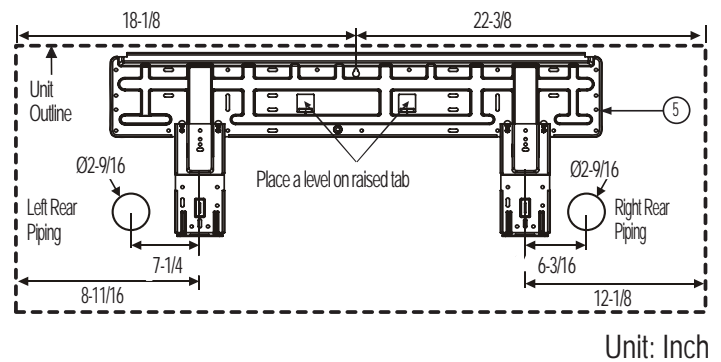

Figure 22: Installation Plate - 180HEV1, 240HEV1



**Note:**

Installation plate for 180HEV, 240HEV can also be used for 180HEV1 and 240HEV1.



# GENERAL INSTALLATION GUIDELINES

## Mounting of Indoor Unit Installation Plate

### Mounting Installation Plate to Wall (Mega 115V - HXV Models)

Follow the procedure and best practices when mounting the indoor unit's plate to a wall.

#### Procedure

1. Mount the installation plate horizontally by aligning the centerline using a leveling tool (Figure 24).
2. Use type "A" screws when mounting the plating (these screws come with the plate).
  - If mounting the unit on concrete wall, use field supplied anchor bolts.
3. Observe the left and right rear piping clearance when drilling into the wall, as shown in Figure 25.

#### Note:

Select location carefully. Unit should be anchored to a strong wall to prevent unnecessary vibration.

#### ⚠ WARNING

- When choosing a location for the wall mount plate, be sure to take into consideration routing of wiring for power outlets within the wall. Contacting wiring can cause serious bodily injury, or death.
- Use caution when drilling holes through the walls for the purposes of piping connections. Power wiring can cause serious bodily injury, or death.

Figure 24: Installation Plate - Mounting Mega 115V

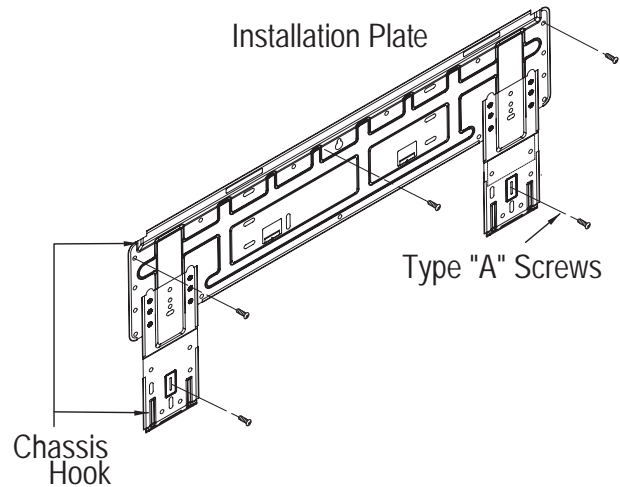

Refer to "Drilling Piping Hole in the Wall" on page 22 as you follow procedure to install plate.

Figure 25: Installation Plate - Mega 115V

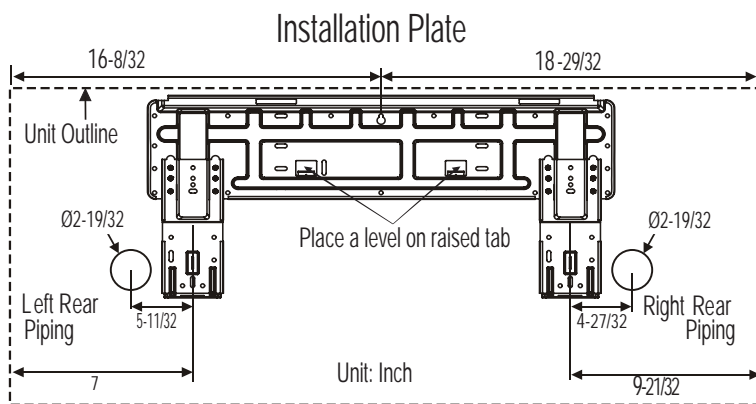

# GENERAL INSTALLATION GUIDELINES

## Mounting of Indoor Unit

### Mounting the Indoor Unit to the Installation Plate

1. Hook the indoor unit onto the upper portion of the installation plate ([1] Figure 26).
2. Engage the hooks at the top of the indoor unit with the upper edge of the installation plate.
  - Ensure that the hooks are properly seated on the installation plate by moving it left and right.
3. Move the bottom of indoor unit towards the installation plate to anchor to wall ([2] Figure 26).
  - It helps to press the lower left and right sides of the unit against the installation plate until the hooks engage into their slots.
  - You will hear a clicking sound as the bottom attaches to the installation plate successfully.
4. Finish by inserting and tightening two type "C" screws into the bottom of the installation plate (Figure 28).
  - Pay attention to the positioning of the piping through any wall as shown in the figure, as you insert the screws to the indoor unit.

#### Preparing for Piping/ Electrical Connection

1. To prepare indoor unit for piping, disengage bottom on indoor unit from installation plate by reversing step 3 from previous procedure.
  - This step will separate the indoor unit's bottom side from the wall mount in order to route drain hose correctly. See Figure 29 for a reference of the rear view of the indoor unit.
2. Swing drain hose holder (L-bracket) out and anchor as shown in Figure 27, against installation plate.
3. Optionally, go to *Refrigerant Piping Connections* section of this manual to continue with piping connections to the indoor unit.
4. Optionally, go to Electrical Connections section of this manual to continue with conduit/electrical wiring to the indoor unit.

Figure 29: Rear View of IDU

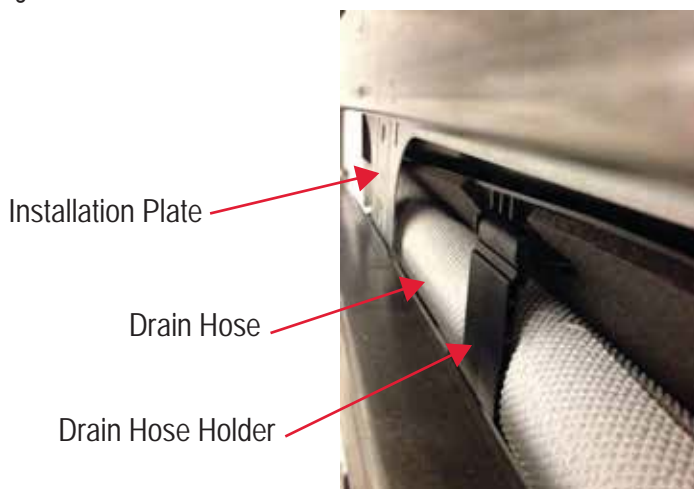

Figure 26: Mounting Unit on Installation Plate

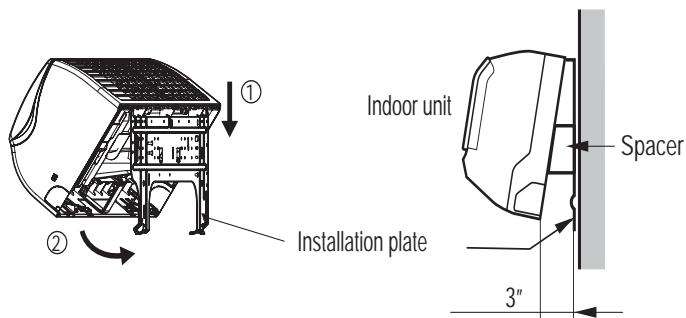

Figure 27: Mounting Unit on Installation Plate

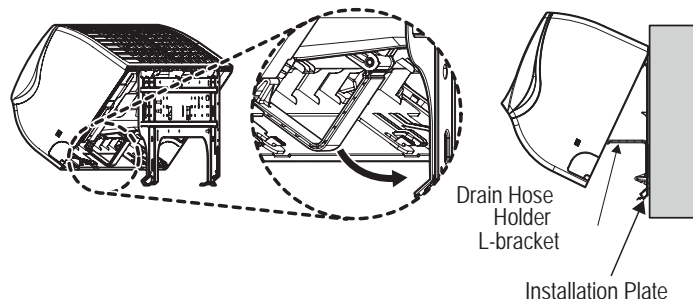
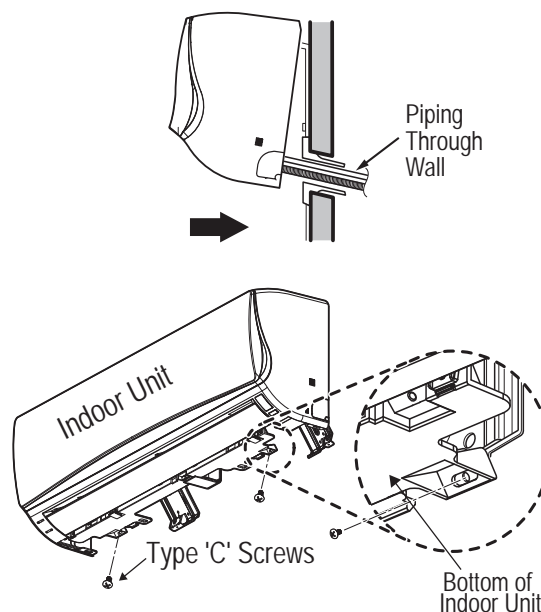

Figure 28: Mounting Bottom of Unit to Installation Plate



# GENERAL INSTALLATION GUIDELINES

## Piping Preparation

### Piping Preparation

#### ⚠ WARNING

- Do not allow the refrigerant to leak during brazing; if the refrigerant combusts, it generates a toxic gas which can cause physical injury or death.
- Do not braze in an enclosed location, and always test for gas leaks before / after brazing. Gas leaks can cause physical injury or death.
- After brazing, check for refrigerant gas leaks. Refrigerant gas leaks can cause physical injury or death.

### Single Zone Pipe Connections

#### Note:

1. Do not use kinked pipe caused by excessive bending in one specific area on its length.
2. Braze the pipes to the service valve pipe stub of the outdoor unit.

### Creating a Flare Fitting

#### Note:

One of the main causes of refrigerant leaks is defective flared connections. Create flared connections using the procedure at right (Figure 31).

1. Cut the pipe to length.
  - Measure the distance between the indoor unit and the outdoor unit.
  - Cut the pipes a little longer than measured distance.
  - Cut the cable 4.9 ft longer than the pipe length.
- 2A. Remove the burrs.
  - Completely remove all burrs from pipe ends.
  - When removing burrs, point the end of the copper pipe down to avoid introducing foreign materials in the pipe.
- 2B. Slide the flare nut onto the copper tube.
3. Flaring the pipe end.
  - Use the proper size flaring tool to finish flared connections as shown.
  - ALWAYS create a 45° flare when working with R410A. See Warning on this page.
4. Carefully inspect the flared pipe end.
  - Compare the geometry with the figure to the right and dimensions as detailed in Figure 30.
  - If the flare is defective, cut it off and re-do procedure.
  - If flare looks good, blow clean the pipe with dry nitrogen.

Figure 30: Dimensions of the Flare

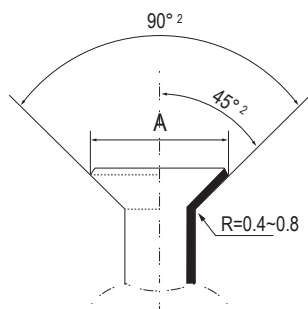

#### ⚠ WARNING

When selecting flare fittings, always use a 45° fitting rated for use with high pressure refrigerant R410A. Failure to do so may result in refrigerant leaks which in turn could result in personal injuries or death from oxygen depletion. Selected fittings must also comply with local, state, or federal standards.

Figure 31: Creating a Flare Fitting

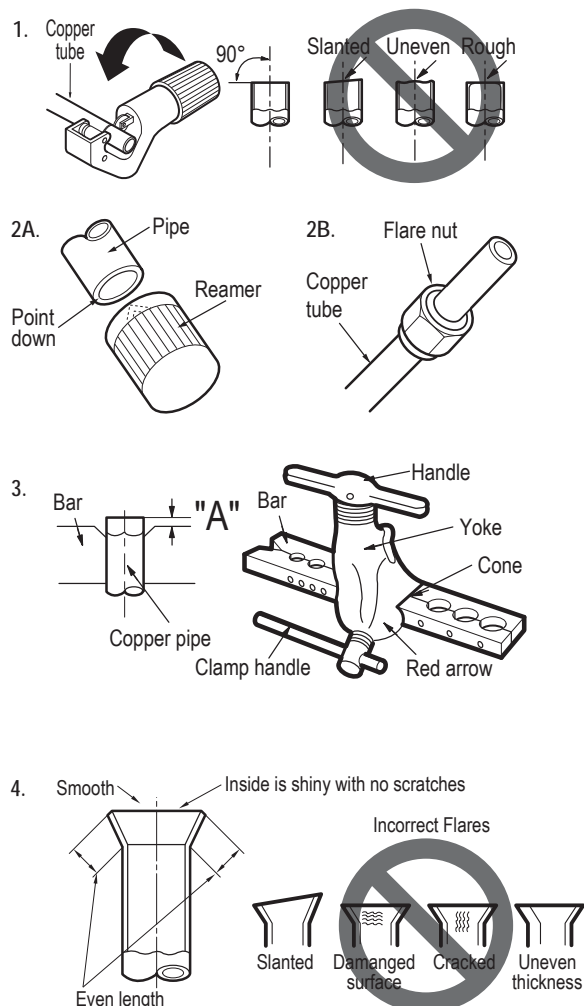

Table 14: Flared Connection Dimensions

Pipe		"A"		Thickness	
Vapor (in. O.D.)	Liquid (in. O.D.)	Vapor (in.)	Liquid (in.)	Vapor (in.)	Liquid (in.)
1/2	1/4	1/8	1/16	1/8	1/8
5/8	3/8	1/8	1/16	1/16	1/8

# GENERAL INSTALLATION GUIDELINES

## Piping Preparation / Piping Materials and Handling

### Tightening the Flare Nuts

Table 15: Tightening Torque for Flare Nuts.

Pipe size (Inches O.D.)	Tightening torque (ft-lbs)	Width of the flare (A [inches])
1/4Ø	13.9 - 18	1/8
3/8Ø	24.5 - 30.3	1/8
1/2Ø	39.7 - 47.7	1/8
5/8Ø	45.5 - 59.2	1/16

1. When connecting the flare nuts, coat the flare (inside and outside) with polyvinyl ether (PVE) refrigeration oil only.
2. Initially hand tighten the flare nuts using three (3) or four (4) turns.
3. To finish tightening the flare nuts, use both a torque wrench and a backup wrench.
4. After all the piping has been connected and the caps have been tightened, check for refrigerant gas leaks.

### Note:

⚠ Do not use polyolylester (POE) or any other type of mineral oil as a thread lubricant. These lubricants are not compatible with PVE oil used in this system and will create oil sludge leading to equipment damage and system malfunction.

### Loosening the Flare Nuts

Always use two (2) wrenches to loosen the flare nuts.

## Piping Materials and Handling

Pipes used for the refrigerant piping system must include the specified thickness, and the interior must be clean.

While handling and storing, do not bend or damage the pipes, and take care not to contaminate the interior with dust, moisture, etc. See Table 16 for care of piping.

Figure 32: Keep Piping Capped While Storing

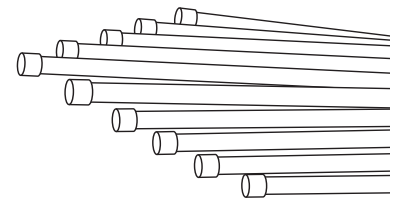
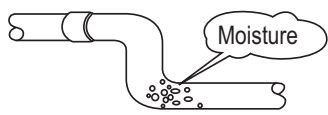
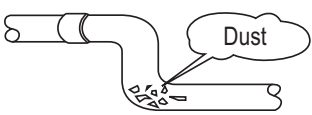
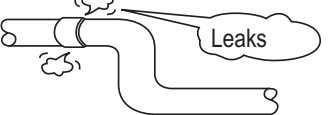

Table 16: Three Principles of Refrigerant Piping

	Dry	Clean	Airtight
Principles	No moisture should be inside the piping.	No dust should be inside the piping.	No leaks should occur.
			
Problems Caused	<ul style="list-style-type: none"> <li>- Significant hydrolysis of refrigerant oil.</li> <li>- Refrigerant oil degradation.</li> <li>- Poor insulation of the compressor.</li> <li>- System does not operate properly.</li> <li>- EEVs, capillary tubes are clogged.</li> </ul>	<ul style="list-style-type: none"> <li>- Refrigerant oil degradation.</li> <li>- Poor insulation of the compressor.</li> <li>- System does not operate properly.</li> <li>- EEVs and capillary tubes become clogged.</li> </ul>	<ul style="list-style-type: none"> <li>- Refrigerant gas leaks / shortages.</li> <li>- Refrigerant oil degradation.</li> <li>- Poor insulation of the compressor.</li> <li>- System does not operate properly.</li> </ul>
Solutions	<ul style="list-style-type: none"> <li>- Remove moisture from the piping.</li> <li>- Piping ends should remain capped until connections are complete.</li> <li>- Do not install piping on a rainy day.</li> <li>- Connect piping properly at the unit's side.</li> <li>- Remove caps only after the piping is cut, the burrs are removed, and after passing the piping through the walls.</li> <li>- Evacuate system to a minimum of 500 microns and insure the vacuum holds at that level for 24 hours</li> </ul>	<ul style="list-style-type: none"> <li>- Remove dust from the piping.</li> <li>- Piping ends should remain capped until connections are complete.</li> <li>- Connect piping properly at the side of the unit.</li> <li>- Remove caps only after the piping is cut and burrs are removed.</li> <li>- Retain the cap on the piping when passing it through walls, etc.</li> </ul>	<ul style="list-style-type: none"> <li>- Test system for air tightness.</li> <li>- Perform brazing procedures that comply with all applicable standards.</li> <li>- Perform flaring procedures that comply with all applicable standards.</li> <li>- Perform flanging procedures that comply with all applicable standards.</li> <li>- Ensure that refrigerant lines are pressure tested to 550 psig.</li> </ul>

# GENERAL INSTALLATION GUIDELINES

## Piping Materials and Handling

### Brazing Practices

**Note:**

Keep the piping system free of contaminants and debris such as copper burrs, slag, or carbon dust during installation. Contaminants can result in mechanical failure of the system.

Figure 33: Refrigerant Pipe Brazing.

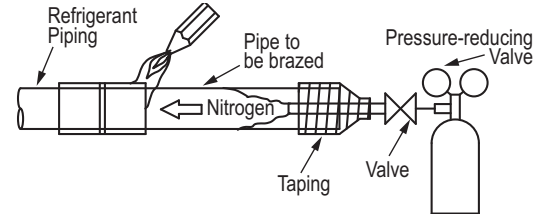

All joints are brazed in the field. Single Zone refrigeration system components contain very small capillary tubes, small orifices, electronic expansion valves, oil separators, and heat exchangers that can easily become blocked. Proper system operation depends on the installer using best practices and utmost care while assembling the piping system.

- While brazing, use a dry nitrogen purge operating at a minimum pressure of three (3) psig and maintain a steady flow.
- Blow clean all pipe sections with dry nitrogen prior to assembly.
- Use a tubing cutter, do not use a saw to cut pipe. De-burr and clean all cuts before assembly.
- Store pipe stock in a dry place. Keep pipe capped and clean.
- Use adapters to assemble different sizes of pipe.
- Do not use flux, soft solder, or anti-oxidant agents.
- Use a 15% silver phosphorous copper brazing alloy to avoid overheating and produce good flow.
- Protect isolation valves, electronic expansion valves, and other heat-sensitive control components from excessive heat with a wet rag or a heat barrier spray product.

### Refrigerant Piping System Insulation

All refrigerant piping from the outdoor unit to the indoor unit must be insulated correctly for safety and usage. Refrigerant piping, service valves, and elbows must be properly and completely insulated using closed cell pipe insulation (up to the indoor unit piping connections). To prevent heat loss / heat gain through the refrigerant piping, all refrigerant piping including liquid lines and vapor lines shall be insulated separately. Insulation shall be a minimum 1/2" thick, and thickness may need to be increased based on ambient conditions and local codes.

Inside the outdoor unit, maximum pipe temperature is 248°F and minimum pipe temperature is -40°F. For field insulation of refrigerant piping between outdoor units and indoor units, consider the following pipe temperature ranges for an operating heat pump system:

- Heating mode refrigerant temperature ranges:   Liquid 75-118°F; High Pressure Vapor   95-220°F
- Cooling mode refrigerant temperature ranges:   Liquid 75-118°F; Low Pressure Vapor       40-90°F

# GENERAL INSTALLATION GUIDELINES

## Piping Materials and Handling

### Selecting Field-Supplied Copper Tubing

Copper is the only approved refrigerant pipe material for use with Single Zone systems products, and LG recommends seamless phosphorous deoxidized ACR type copper pipe, hard-drawn rigid type “K” or “L”, or annealed-tempered, copper pipe.

- Drawn temper (rigid) ACR copper tubing is available in sizes 3/8 through 2-1/8 inches (ASTM B 280, clean, dry, and capped).
- Annealed temper (soft) ACR copper tubing is available in sizes 1/4 through 2-1/8 inches (ASTM B 280, clean, dry, and capped).

**Note:**

Tube wall thickness should meet local code requirements and be approved for an operating pressure of 551 psi. If local code does not specify wall thickness, LG suggests using tube thickness per table below. When bending tubing, try to keep the number of bends to a minimum, and use the largest radii possible to reduce the equivalent length of installed pipe; also, bending radii greater than ten (10) pipe diameters can minimize pressure drop. Be sure no traps or sags are present when rolling out soft copper tubing coils.

Table 17: ACR Copper Tubing Material

Type	Seamless Phosphorous Deoxidized
Class	UNS C12200 DHP
Straight Lengths	H58 Temper
Coils	O60 Temper

Table 18: Piping Tube Thicknesses

OD (in)	1/4	3/8	1/2	5/8	3/4	7/8	1-1/8	1-3/8	1-5/8
Material	Rigid Type “K” or “L” and Soft ACR Acceptable			Rigid Type “K” or “L” Only					
Min. Bend Radius (in)	.563	.9375	1.5	2.25	3.0	3.0	3.5	4.0	4.5
Min. Wall Thickness (in)	.03	.03	.035	.040	.042	.045	.050	.050	.050

Table 19: ACR Copper Tubing Dimensions and Physical Characteristics<sup>1-4</sup>

Nominal Pipe Outside Diameter (in)	Actual Outside Diameter (in)	Drawn Temper			Annealed Temper		
		Nominal Wall Thickness (in)	Weight (lb/ft)	Cubic ft per Linear ft	Nominal Wall Thickness (in)	Weight (lb/ft)	Cubic ft per Linear ft
1/4	0.250	--	--	--	0.030	0.081	.00020
3/8	0.375	0.030	0.126	.00054	0.032	0.134	.00053
1/2	0.500	0.035	0.198	.00101	0.032	0.182	.00103
5/8	0.625	0.040	0.285	.00162	0.035	0.251	.00168
3/4	0.750	0.042	0.362	.00242	0.042	0.362	.00242
7/8	0.875	0.045	0.455	.00336	0.045	0.455	.00336
1-1/8	1.125	0.050	0.655	.00573	0.050	0.655	.00573

<sup>1</sup>All dimensions provided are in accordance with ASTM B280 – Standard.

<sup>2</sup>Design pressure = 551 psig.

<sup>3</sup>ACR Tubing is available as hard drawn or annealed (soft) and are suitable for use with R410A refrigerant.

<sup>4</sup>The Copper Tube Handbook, 2010, Copper Development Association Inc., 260 Madison Avenue, New York, NY 10016.

**Note:**

- Commercially available piping often contains dust and other materials. Always blow it clean with a dry inert gas.
- Prevent dust, water or other contaminants from entering the piping during installation. Contaminants can cause mechanical failure.

# GENERAL INSTALLATION GUIDELINES

## Piping Materials and Handling

### No Pipe Size Substitutions

#### Note:

Use only the pipe size recommended by this installation manual. Using a different size is prohibited and may result in a system malfunction or failure to work at all.

### Obstacles

When an obstacle, such as an I-beam or concrete T, is in the path of the planned refrigerant pipe run, it is best practice to route the pipe over the obstacle. If adequate space is not available to route the insulated pipe over the obstacle, then route the pipe under the obstacle. In either case, it is imperative the length of the horizontal section of pipe above or below the obstacle be a minimum of three (3) times the longest vertical rise (or fall) at either end of the segment.

### Copper Expansion and Contraction

Under normal operating conditions, the vapor pipe temperature of a Duct Free System can vary as much as 280°F. With this large variance in pipe temperature, the designer must consider pipe expansion and contraction to avoid pipe and fitting fatigue failures.

Refrigerant pipe along with the insulation jacket form a cohesive unit that expands and contracts together. During system operation, thermal heat transfer occurs between the pipe and the surrounding insulation.

If the pipe is mounted in free air space, no natural restriction to movement is present if mounting clamps are properly spaced and installed. When the refrigerant pipe is mounted underground in a utility duct stacked among other pipes, natural restriction to linear movement is present. In extreme cases, the restrictive force of surface friction between insulating jackets could become so great that natural expansion ceases and the pipe is “fixed” in place. In this situation, opposing force caused by change in refrigerant fluid/vapor temperature can lead to pipe/fitting stress failure.

The refrigerant pipe support system must be engineered to allow free expansion to occur. When a segment of pipe is mounted between two fixed points, provisions must be provided to allow pipe expansion to naturally occur. The most common method is the inclusion of expansion Loop or U-bends. Each segment of pipe has a natural fixed point where no movement occurs. This fixed point is located at the center point of the segment assuming the entire pipe is insulated in a similar fashion. The natural fixed point of the pipe segment is typically where the expansion Loop or U-bend should be.

Linear pipe expansion can be calculated using the following formula:  
 $LE = C \times L \times (T_r - T_a) \times 12$

LE	=	Anticipated linear tubing expansion (in.)
C	=	Constant (For copper = $9.2 \times 10^{-6}$ in./in.°F)
L	=	Length of pipe (ft.)
$T_r$	=	Refrigerant pipe temperature (°F)
$T_a$	=	Ambient air temperature (°F)
12	=	Inches to feet conversion (12 in./ft.)

Figure 34: Installing Piping Above and Below an Obstacle.

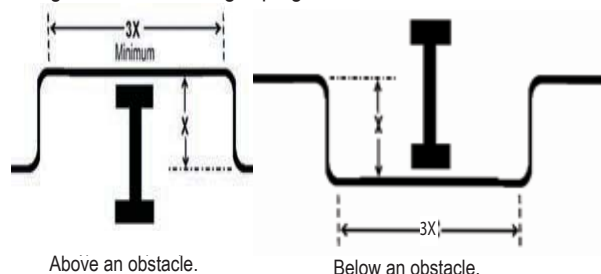

1. From Table 20 find the row corresponding with the actual length of the straight pipe segment.
2. Estimate the minimum and maximum temperature of the pipe. In the column showing the minimum pipe temperature, look up the anticipated expansion distance. Do the same for the maximum pipe temperature.
3. Calculate the difference in the two expansion distance values. The result will be the anticipated change in pipe length.

#### Example:

A system is installed and the design shows that there is a 100 foot straight segment of tubing between an indoor unit and the outdoor unit. In heating, this pipe transports hot gas vapor to the indoor units at 120 °F. In cooling, the same tube is a suction line returning refrigerant vapor to the outdoor unit at 40 °F. Look up the copper tubing expansion at each temperature and calculate the difference.

#### Vapor Line

Transporting Hot Vapor: 100 ft. pipe at 120 °F = 1.40 in.  
 Transporting Suction Vapor: 100 ft. pipe at 40 °F = 0.40 in.  
 Anticipated Change in Length: 1.40 in. – 0.40 in. = 1.00 in.

#### Liquid Line

The liquid temperature remains relatively the same temperature; only the direction of flow will reverse. Therefore, no significant change in length of the liquid line is anticipated.

When creating an expansion joint, the joint height should be a minimum of two times the joint width. Although different types of expansion arrangements are available, the data for correctly sizing an Expansion Loop is provided in Table 21. Use soft copper with long radius bends on longer runs or long radius elbows for shorter pipe segments. Using the anticipated linear expansion (LE) distance calculated, look up the Expansion Loop or U-bend minimum design dimensions. If other types of expansion joints are chosen, design per ASTM B-88 Standards.

# GENERAL INSTALLATION GUIDELINES

## Piping Materials and Handling

See table below for precalculated anticipated expansion for various pipe sizes and lengths of refrigerant tubing.

To find the anticipated expansion value:

1. From the table below, find the row corresponding with the actual feet of the straight pipe segment.
2. Estimate the minimum and maximum temperature of the pipe.
3. In the column showing the minimum pipe temperature, look up the anticipated expansion distance corresponding to the segment length. Do the same for the maximum pipe temperature.
4. Calculate the difference in the two expansion distance values. The result will be the change in pipe length.

Table 20: Linear Thermal Expansion of Copper Tubing in Inches

Pipe Length <sup>1</sup>	Fluid Temperature °F																			
	35°	40°	45°	50°	55°	60°	65°	70°	75°	80°	85°	90°	95°	100°	105°	110°	115°	120°	125°	130°
10	0.04	0.04	0.05	0.06	0.06	0.07	0.08	0.08	0.09	0.09	0.10	0.10	0.11	0.11	0.11	0.12	0.13	0.14	0.15	0.15
20	0.08	0.08	0.10	0.12	0.13	0.14	0.15	0.16	0.17	0.18	0.19	0.20	0.21	0.22	0.22	0.23	0.26	0.28	0.29	0.30
30	0.12	0.12	0.15	0.18	0.20	0.21	0.23	0.24	0.26	0.27	0.29	0.30	0.32	0.33	0.32	0.35	0.39	0.42	0.44	0.45
40	0.16	0.16	0.20	0.24	0.26	0.28	0.30	0.32	0.34	0.36	0.38	0.40	0.42	0.44	0.43	0.46	0.52	0.56	0.58	0.60
50	0.20	0.20	0.25	0.30	0.33	0.35	0.38	0.40	0.43	0.45	0.48	0.50	0.53	0.55	0.54	0.58	0.65	0.70	0.73	0.75
60	0.24	0.24	0.30	0.36	0.39	0.42	0.45	0.48	0.51	0.54	0.57	0.60	0.63	0.66	0.65	0.69	0.78	0.84	0.87	0.90

<sup>1</sup>Pipe length baseline temperature = 0°F. "Expansion of Carbon, Copper and Stainless Steel Pipe," *The Engineers' Toolbox*, www.engineeringtoolbox.com.

Figure 35: Coiled Expansion Loops and Offsets

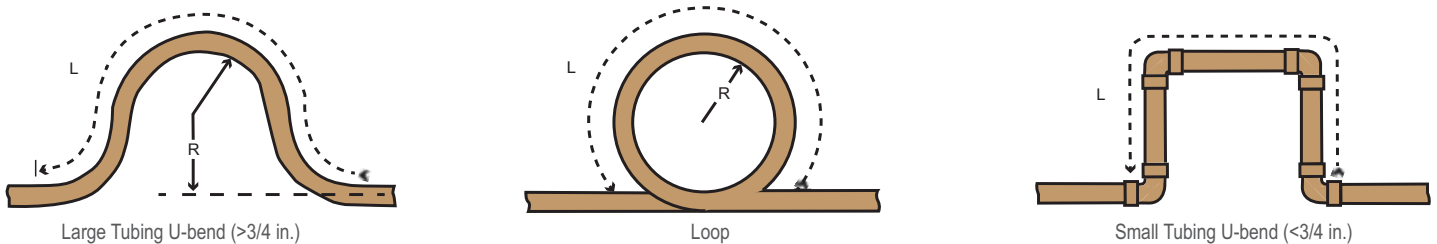

Table 21: Radii of Coiled Expansion Loops and Developed Lengths of Expansion Offsets

Anticipated Linear Expansion (LE) (inches)		Nominal Tube Size (OD) inches			
		1/4	3/8	1/2	3/4
1/2	R <sup>1</sup>	6	7	8	9
	L <sup>2</sup>	38	44	50	59
1	R <sup>1</sup>	9	10	11	13
	L <sup>2</sup>	54	63	70	83
1-1/2	R <sup>1</sup>	11	12	14	16
	L <sup>2</sup>	66	77	86	101
2	R <sup>1</sup>	12	14	16	19
	L <sup>2</sup>	77	89	99	117
2-1/2	R <sup>1</sup>	14	16	18	21
	L <sup>2</sup>	86	99	111	131
3	R <sup>1</sup>	15	17	19	23
	L <sup>2</sup>	94	109	122	143
3-1/2	R <sup>1</sup>	16	19	21	25
	L <sup>2</sup>	102	117	131	155
4	R <sup>1</sup>	17	20	22	26
	L <sup>2</sup>	109	126	140	166



# GENERAL INSTALLATION GUIDELINES

## Piping Materials and Handling

### Pipe Bends

When bending soft copper, use long radius bends. Refer to the “Radii of Coiled Expansion Loops and Developed Lengths of Expansion Offsets” table for minimum radius specifications, as shown on previous page.

### In-line Refrigeration Components



Components such as oil traps, solenoid valves, filter-dryers, sight glasses, tee fittings, and other after-market accessories are not permitted on the refrigerant piping system between the outdoor unit and the indoor unit.

Single Zone systems are provided with redundant systems that assure oil is properly returned to the compressor. Sight-glasses and solenoid valves may cause vapor to form in the liquid stream.

#### Note:

Over time, dryers may deteriorate and introduce debris into the system. The designer and installer should verify the refrigerant piping system is free of traps, sagging pipes, sight glasses, filter dryers, etc.

### Using Elbows

Field-supplied elbows are allowed as long as they are designed for use with R410A refrigerant. The designer, however, should be cautious with the quantity and size of fittings used, and must account for the additional pressure losses in equivalent pipe length calculation. The equivalent pipe length of each elbow must be added to each pipe segment (Table 22).

Table 22: Equivalent Piping Length for Piping Components

Component	Size (Inches)				
Elbow (ft.)	1/4	3/8	1/2	5/8	3/4
	0.5	0.6	0.7	0.8	1.2

### Pipe Supports

#### Note:

A properly installed pipe system should be adequately supported to avoid pipe sagging. Sagging pipes become oil traps that lead to equipment malfunction.

Pipe supports should never touch the pipe wall; supports shall be installed outside (around) the primary pipe insulation jacket (see Figure 36). Insulate the pipe first because pipe supports shall be installed outside (around) the primary pipe insulation jacket. Clevis hangers should be used with shields between the hangers and insulation. Field provided pipe supports should be designed to meet local codes. If allowed by code, use fiber straps or split-ring hangers suspended from the ceiling on all-thread rods (fiber straps or split ring hangers can be used as long as they do not compress the pipe insulation). Place a second layer of insulation over the pipe insulation jacket to prevent chafing and compression of the primary insulation within the confines of the support pipe clamp.

Figure 36: Pipe Hanger Details

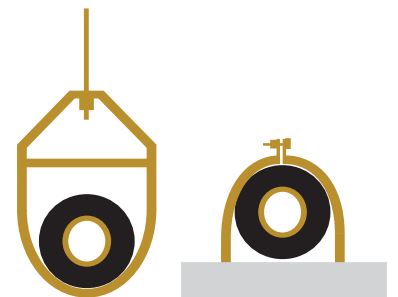

# GENERAL INSTALLATION GUIDELINES

## Piping Support, Elbow Usage

### Pipe Supports, continued.

A properly installed pipe system will have sufficient supports to avoid pipes from sagging during the life of the system. As necessary, place supports closer for segments where potential sagging could occur. Maximum spacing of pipe supports shall meet local codes.

If local codes do not specify pipe support spacing, pipe shall be supported:

- Maximum of five feet (5') on center for straight segments of pipe up to 3/4" outside diameter size.
- Maximum of six feet (6') on center for pipe up to one inch (1") outside diameter size.
- Maximum of eight feet (8') on center for pipe up to two inches (2") outside diameter size.

Wherever the pipe changes direction, place pipe clamps within twelve (12) inches on one side and within twelve to nineteen (12 to 19) inches of the bend on the other side as shown in Figure 37.

Figure 37: Typical Pipe Support Location—Change in Pipe Direction

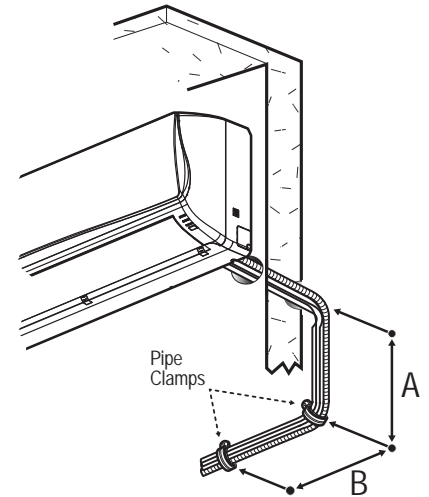

### Pipe Sleeves at Penetrations

LG requires that all pipe penetrations through walls, floors, and pipes buried underground be properly insulated and routed through an appropriate wall sleeve of sufficient size to prevent compression of refrigerant pipe insulation and free movement of the pipe within the sleeve (Figure 38). Underground refrigerant pipe shall be routed inside a protective sleeve to prevent insulation deterioration. Refer to Figure 39.

Figure 38: Pipe Sleeve Options.

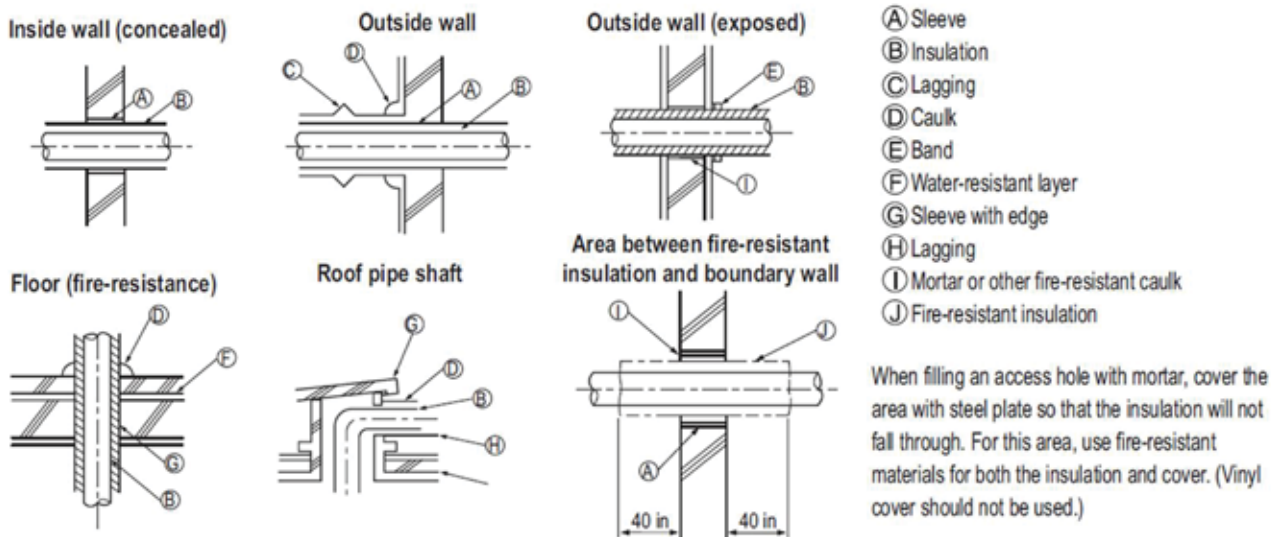

### Note

Diameter of penetrations shall be determined by pipe diameter plus the thickness of the insulation.

# GENERAL INSTALLATION GUIDELINES

## Refrigerant Piping System Layout

### Underground Refrigerant Piping

Refrigerant pipe installed underground should be routed inside a vapor tight protective sleeve to prevent insulation deterioration and water infiltration. Refrigerant pipe installed inside underground casing must be continuous without any joints. Underground refrigerant pipe must be located at a level below the frost line.

Table 23: Utility Conduit Sizes.

Liquid Pipe <sup>1</sup>	Vapor Pipe <sup>1</sup>		
	3/8 (1-1/8 <sup>2,3</sup> )	1/2 (2.0 <sup>2,4</sup> )	5/8 (2-1/8 <sup>2,4</sup> )
1/4 (1.0) <sup>3</sup>	4	4	4
3/8 (1-1/8) <sup>3</sup>	4	4	4

<sup>1</sup>OD pipe diameter in inches; Values in parenthesis () indicate OD of pipe with insulation jacket.

<sup>2</sup>Diameter of pipe with insulation. Thickness of pipe insulation is typical. Actual required thickness may vary based on surrounding ambient conditions and should be calculated and specified by the design engineer.

<sup>3</sup>Insulation thickness (value in parenthesis) = 3/8 inch.

<sup>4</sup>Insulation thickness (value in parenthesis) = 1 inch.

Figure 39: Typical Arrangement of Refrigerant Pipe and Cable(s) in a Utility Conduit.

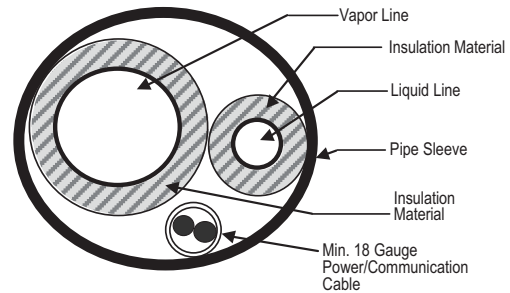

Table 24: Heat Pump Unit Refrigerant Pipe Connections (All Brazed Type)

Model	Liquid Conn. (inches)	Vapor Conn. (inches)
LSU091HSV3, LSU121HSV3	1/4	3/8
LSU181HSV3, LSU240HSV3	3/8	5/8
LSU307HV3, LSU360HV3	3/8	5/8
LSU240HLV, LSU300HLV, LSU360HLV	3/8	5/8
LSU090HEV, LSU120HEV, LSU090HEV1, LSU120HEV1, LSU090HXV, LSU120HXV	1/4	3/8
LSU180HEV, LSU180HEV1	1/4	1/2
LSU240HEV, LSU240HEV1	1/4	5/8

# REFRIGERANT PIPING CONNECTIONS

## Refrigerant Piping System Limitations

### Connection Limitations

Single zone systems consist of one outdoor unit and one indoor unit. One of the most critical elements of a single zone system is the refrigerant piping. Tables 25 to 28 list pipe length limits that must be followed in the design of a Single Zone Wall Mount refrigerant pipe system. Refer to Figure 40 for maximum length and elevation of piping.

Table 25: Single Zone High Efficiency Refrigerant Piping System Limitations

Pipe Length (ELF = Equivalent Length of pipe in Feet)	Longest total equivalent piping length	LS091HSV3	LS121HSV3	LS181HSV3	LS240HSV3
		Shortest total equivalent piping length	65.6	65.6	98.4
	Distance between fittings and indoor units or outdoor units	6.6	6.6	9.8	9.8
Elevation (All Elevation Limitations are Measured in Actual Feet)	If outdoor unit is above indoor unit	≥20 inches	≥20 inches	≥20 inches	≥20 inches
	If outdoor unit is below indoor unit	32.8	32.8	49.2	49.2
Additional Refrigerant Needed (oz/ft)		32.8	32.8	49.2	49.2
		0.22	0.22	0.38	0.38

Table 26: Single Zone Standard Refrigerant Piping System Limitations

Pipe Length (ELF = Equivalent Length of pipe in Feet)	Longest total equivalent piping length	LS307HV3	LS360HV3
		Shortest total equivalent piping length	98.4
	Distance between fittings and indoor units or outdoor units	9.8	9.8
Elevation (All Elevation Limitations are Measured in Actual Feet)	If outdoor unit is above indoor unit	≥20 inches	≥20 inches
	If outdoor unit is below indoor unit	49.2	49.2
Additional Refrigerant Needed (oz/ft)		49.2	49.2
		0.38	0.38

Figure 40: Single Zone System Layout

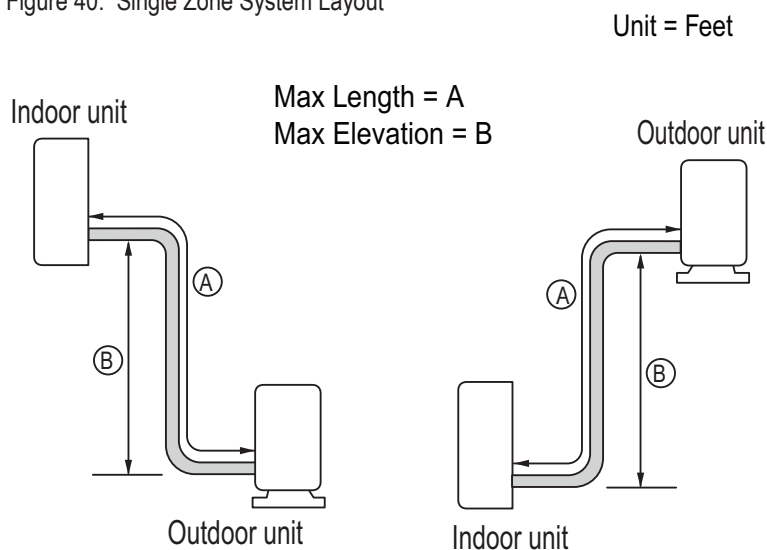

# REFRIGERANT PIPING CONNECTIONS

## Refrigerant Piping System Limitations

### Connection Limitations - Continued

Table 27: Single Zone Extended Pipe Refrigerant Piping System Limitations

Pipe Length (ELF = Equivalent Length of pipe in Feet)	Longest total equivalent piping length	LS240HLV	LS300HLV	LS360HLV
		164.0	164.0	164.0
	Shortest total equivalent piping length	9.8	9.8	9.8
	Distance between fittings and indoor units or outdoor units	≥20 inches	≥20 inches	≥20 inches
Elevation (All Elevation Limitations are Measured in Actual Feet)	If outdoor unit is above indoor unit	98.4	98.4	98.4
	If outdoor unit is below indoor unit	98.4	98.4	98.4
Additional Refrigerant Needed (oz/ft)		0.38	0.38	0.38

Table 28: Single Zone Mega (HEV and HEV1) / Mega 115V Pipe Refrigerant Piping System Limitations

Pipe Length (ELF = Equivalent Length of pipe in Feet)	Longest total equivalent piping length	LS090HEV, LS090HEV1/ LS120HEV, LS120HEV1	LS180HEV, LS180HEV1/ LS240HEV, LS240HEV1	LS090HXV/ LS120HXV
		49.2	65.6	49.2
	Shortest total equivalent piping length	9.8	9.8	9.8
	Distance between fittings and indoor or outdoor units	≥20 inches	≥20 inches	≥20 inches
Elevation (All Elevation Limitations are Measured in Actual Feet)	If outdoor unit is above indoor unit	22.9	32.8	23
	If outdoor unit is below indoor unit	22.9	32.8	23
Additional Refrigerant Needed (oz/ft)		0.22	0.33	0.22

# REFRIGERANT PIPING CONNECTIONS

## Installation Overview

### Installation

Single Zone Wall-Mounted systems are one-to-one systems. There is a direct piping connection between the outdoor unit and the indoor unit. Figure 41 illustrates the basic pipe connections between the outdoor and indoor unit. Refer back to this illustration as you proceed with pipe connections. This illustration shows the indoor unit being installed at a higher position than the outdoor unit. However, should you install the outdoor unit at a higher position than the indoor unit, the basic pipe connections should be the same.

Refer back to the tables within the *“Connection Limitations”* section, on the previous page, for specific length limitations in conjunction with outdoor unit and indoor unit positioning.

**Note:**

- As you proceed with the piping connections be sure to adhere to pipe support spacing lengths as shown in Figure 42 below. Refer back to “Pipe Supports” section for in-depth information regarding using elbows, clamps and pipe supporting materials.
- Always adhere to local codes regarding piping and accurate support spacing along the outdoor pipe line.

Figure 42: Pipe Support Lengths - Outdoors

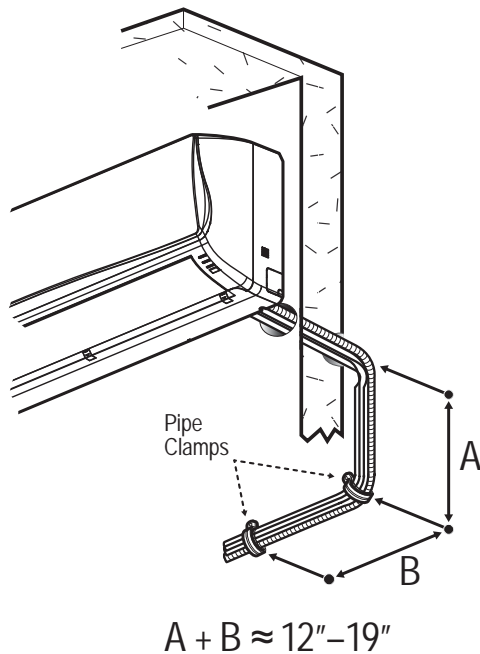
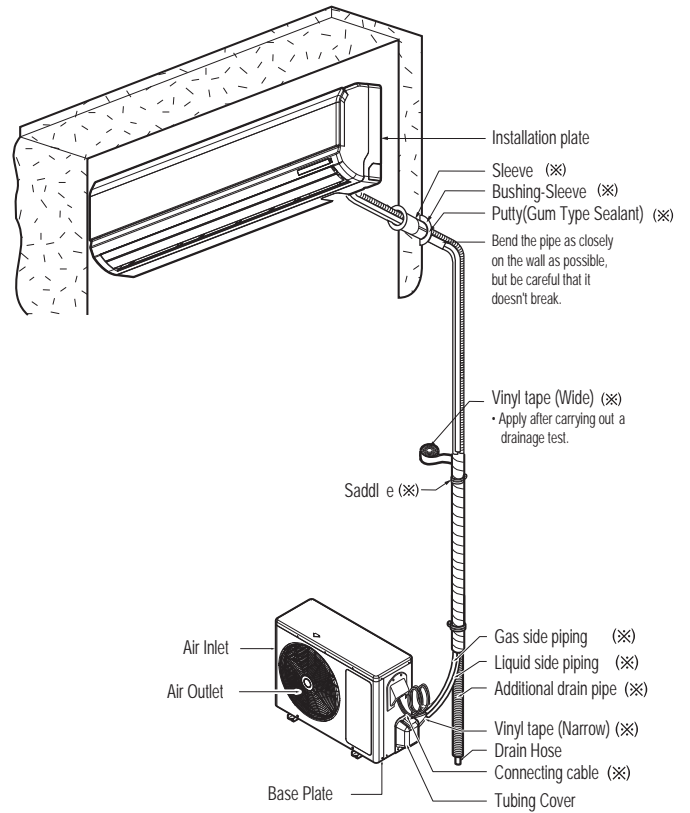

Figure 41: Installation and Piping Connection Overview

### Installation Overview



(※) Additional accessories/parts/tools that will be needed for installation but are not provided by LG.

# REFRIGERANT PIPING CONNECTIONS

## Directional Pipe Formation

### Pipe Bundling

See Figure 43 for proper pipe and cable bundling. Note the placement of the piping along with the necessary insulation material.

1. Be sure to wrap each pipe with proper insulation material.
2. Secure the piping by wrapping vinyl tape around the pipe.
  - Use the narrow size tape for wrapping the actual pipe.
3. You can include the drain hose within the bundled piping and wrap all of them together using the wider vinyl tape as shown in Figure 44.
- The end of the drain hose outlet must be routed above the ground.

Figure 43: Cutaway of Proper Pipe and Cable Bundling

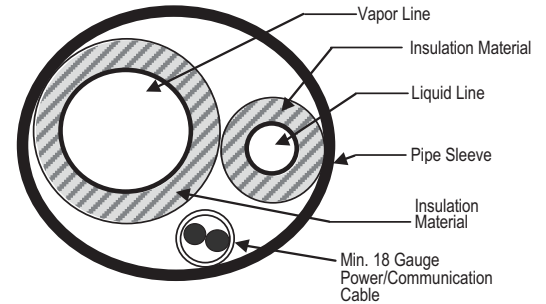

### Indoor Unit Installed Above Outdoor Unit

1. Refer to Figure 45 while following the procedures below.
2. Tape the piping, drain hose and connecting cable from down to up.
3. Secure the taped piping along the exterior wall using pipe clamps.
4. Create trap above the electrical connections cover, in order to prevent water from penetrating electrical components and wiring.

Figure 44: Bundling and Taping

### Bundling Piping

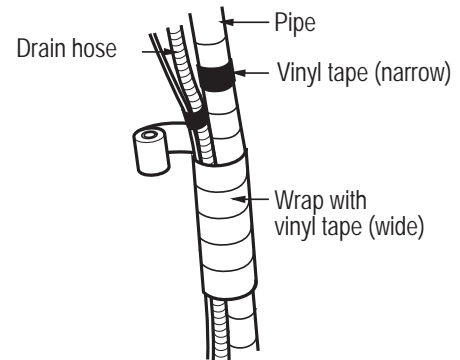

### Indoor Unit Installed Below Outdoor Unit

1. Refer to Figure 46 while following the procedures below.
2. Tape the piping, drain hose and connection cable from down to up.
3. Secure the taped piping along the exterior wall using pipe clamps.
4. Create trap above the electrical connections cover, in order to prevent water from entering the room.

Figure 45: IDU Above ODU - Piping and Trap

### Indoor Unit Installed ABOVE Outdoor Unit - Piping/Trap

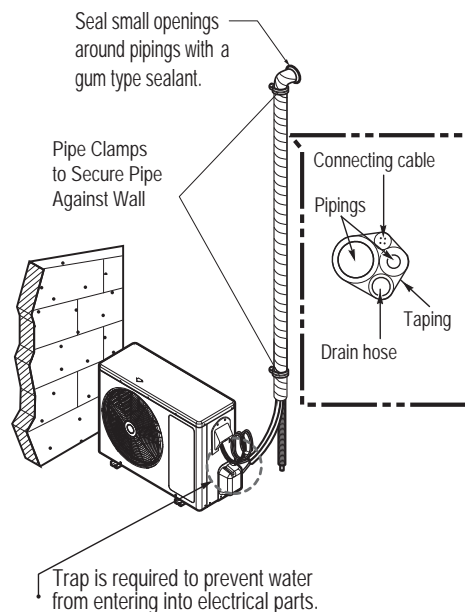
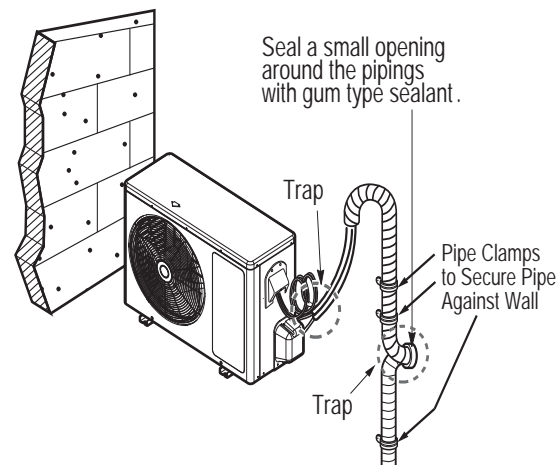

Figure 46: IDU Below ODU - Piping and Trap

### Indoor Unit Installed BELOW Outdoor Unit - Piping/Trap



# REFRIGERANT PIPING CONNECTIONS

## Drain Hose

### Indoor Unit Drain Hose Guidelines

**Note:**

Refer to the diagrams below and follow proper installation and the running of the drain hose along the pipe installation line to avoid leakage. Once drain hose is set in place, always follow with evacuation and leakage testing of all piping to be sure all piping is properly sealed. Re-check and retest as necessary.

Drain hose is routed from the indoor unit through the structure (wall) to the outdoor. It should slope at an angle where it is higher at the indoor unit and lower toward the outdoor area, thereby letting gravity push any condensation down and out. See Figure 47 for proper drainage slope. Avoid piping the drain hose as shown in Figure 48. These methods are incorrect and can cause leakage at the indoor unit site.

Figure 47: Correct Slope Angle for Drain Hose

Correct Drainage Slope

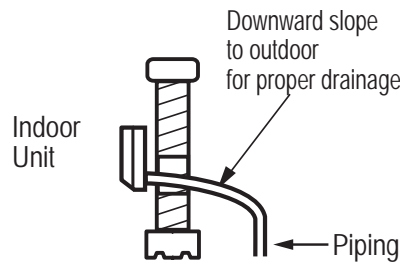
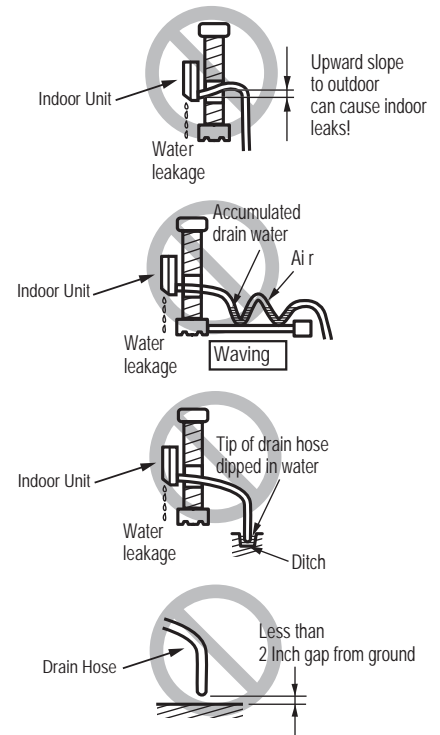

Figure 48: Correct Slope Angle for Drain Hose

Incorrect Drainage Setup



### Outdoor Unit Drain Hose Guidelines

Depending on installation site, it may be necessary to install a drain plug (factory supplied).

1. See the figures below for drain plug installation.
2. Connect a field-supplied hose to the drain connection (A). If the hose is too long, position it carefully to prevent kinks.

Table 29: Outdoor Unit Drain Connection Legend

Label	Component
A	Drain Connection
B	Drain Cap
C	Drain Washer

**Note:**

Do not use a drain hose with the outdoor unit in cold climates, otherwise the drain water may freeze and impair heating performance.

Figure 49: HSV3 and HV3 Outdoor Unit Drain Connection Components

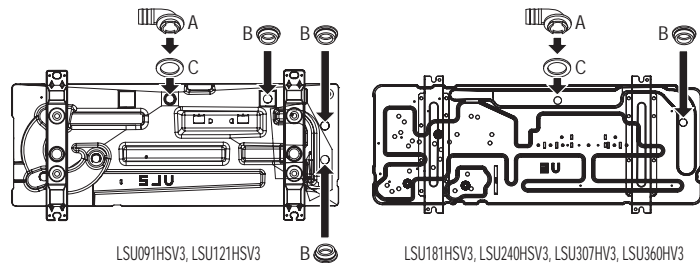

Figure 50: HXV and HLV Outdoor Unit Drain Connection Components

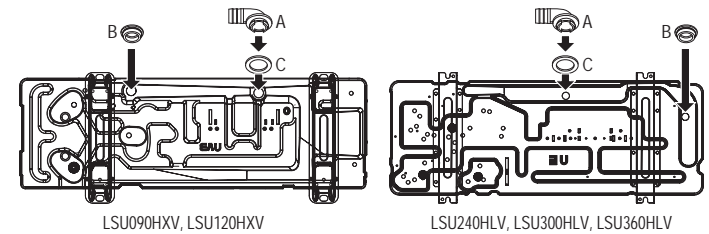
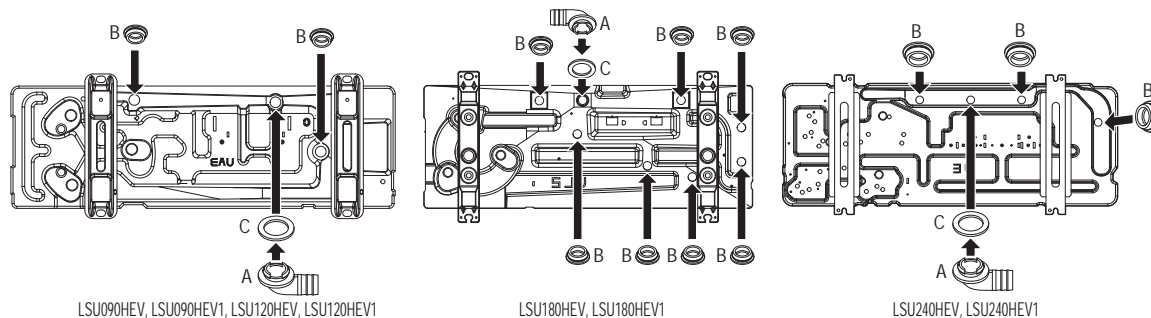

Figure 51: HEV and HEV1 Outdoor Unit Drain Connection Components.



Due to our policy of continuous product innovation, some specifications may change without notification. ©LG Electronics U.S.A., Inc., Englewood Cliffs, NJ. All rights reserved. "LG" is a registered trademark of LG Corp.





# REFRIGERANT PIPING CONNECTIONS

## Outdoor Unit Connections

### Single Zone Wall Mount Outdoor Unit Connections (HSV3, HV3, HLV)

1. Remove the tubing cover by loosening the fastening screws. See Figures 52 and 53.
2. Align the center of the refrigerant pipe and corresponding connection as shown below.
3. Refer to Figure 54 (for HSV3) and Figure 55 (for HV3, HLV) for correct liquid and gas pipe attachment onto outdoor unit.
4. Place a couple of drops of refrigerant oil on the opening rim of the flare before assembling. Ensure you do not add any contaminants. Tighten the flare nut initially by hand.
5. Finish tightening the flare nut with a torque wrench until the wrench clicks. Follow torque guidelines in Table 30. See figures for correct connection points.

Figure 52: Outdoor Unit Connection Cover Removal (HSV3)

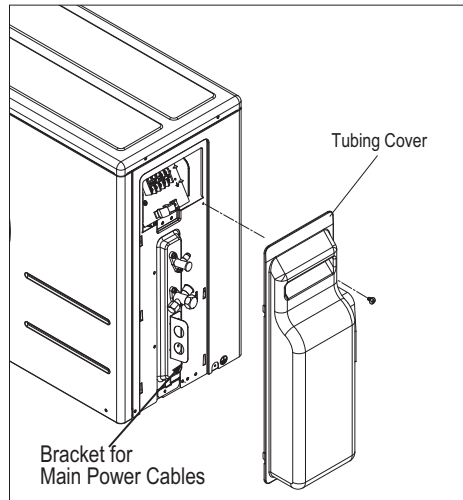

Figure 53: Outdoor Unit Connection Cover Removal (HV3, HLV)

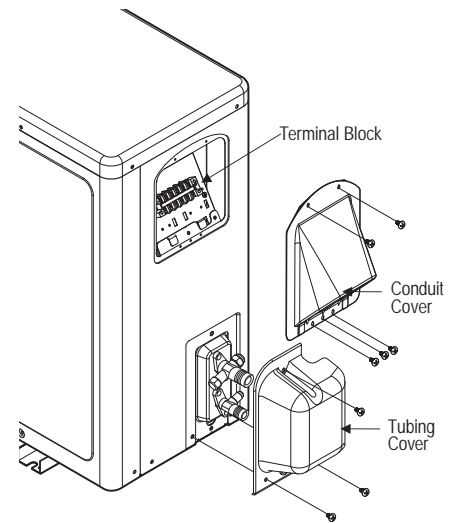

Figure 54: Outdoor Unit Piping Connection (HSV3)

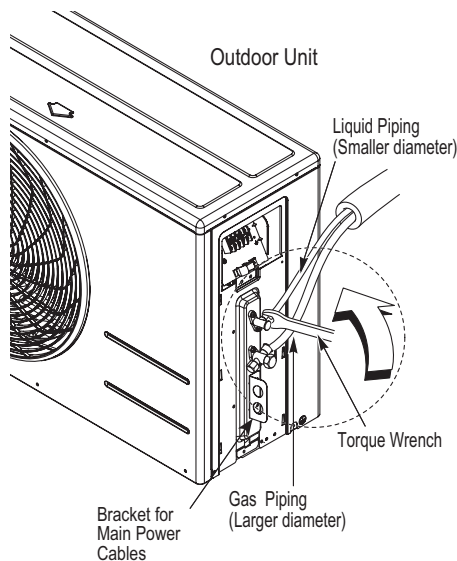

Figure 55: Outdoor Unit Piping Connection (HV3, HLV)

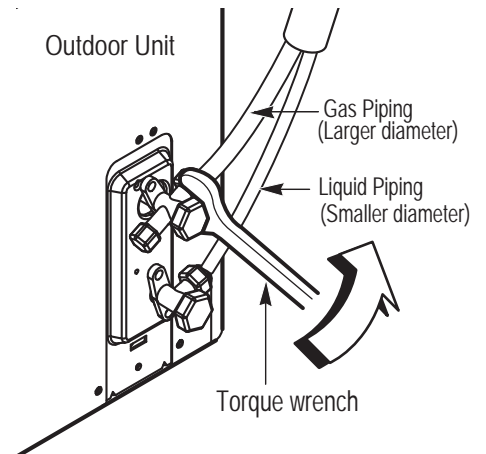
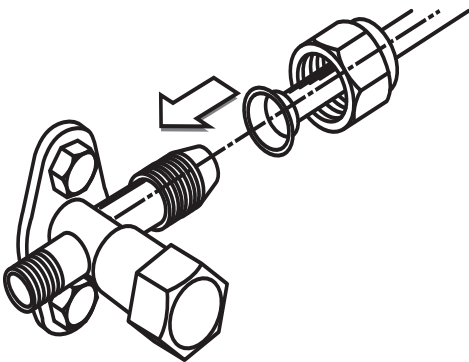

Figure 56: Pipe Attachment



#### Note:

When tightening the flare nut with a torque wrench, ensure the direction for tightening follows the arrow on the wrench.

Table 30: Torque Wrench Tightening

Outside Diameter (inches)	Torque (lbs-ft)
1/4	13-18
3/8	24.6-30.4
1/2	39.8-47.7
5/8	45.6-59.3

#### Note:

⊘ Do not thread liquid or gas piping through bracket used to hold main power cables (for HSV3 model).

# REFRIGERANT PIPING CONNECTIONS

## Outdoor Unit Connections

### Single Zone Wall Mount Outdoor Unit Connections (090HEV, 090HEV1, 120HEV, 120HEV1, 240HEV, 240HEV1, 090HXV, 120HXV)

1. Remove the tubing cover by loosening the fastening screws (Figures 57 to 59).
2. Align the center of the refrigerant pipe and corresponding connection as shown in Figure 60.
3. Refer to Figures 61 to 63 for correct liquid and gas pipe attachment onto outdoor unit.
4. Place a couple of drops of refrigerant oil on the opening rim of the flare before assembling. Ensure you do not add any contaminants. Tighten the flare nut initially by hand.
5. Finish tightening the flare nut with a torque wrench until the wrench clicks. Follow the guidelines as outlined in Table 31 for the amount of torque to use.

Figure 57: LSU90-120HEV/HEV1, LSU90-120HXV Outdoor Unit Connection Cover Removal

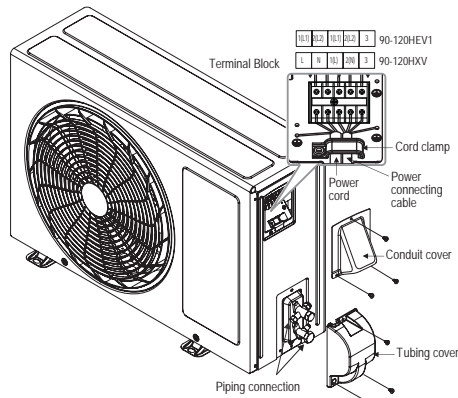

Figure 58: LSU180HEV/HEV1 Outdoor Unit Connection Cover Removal

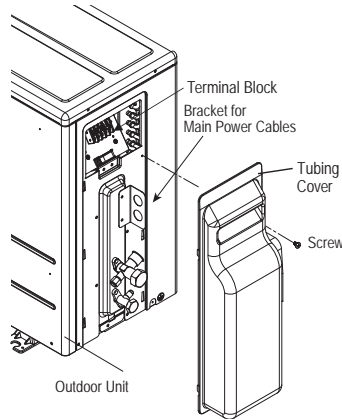

Figure 59: LSU240HEV/HEV1 Outdoor Unit Connection Cover Removal

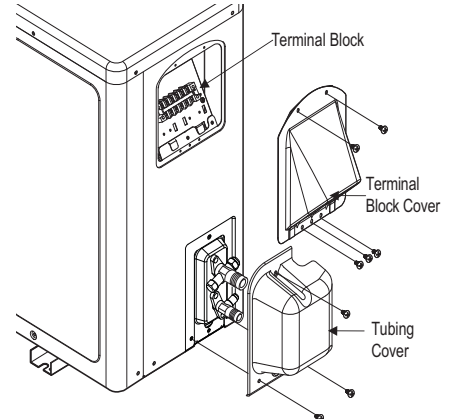
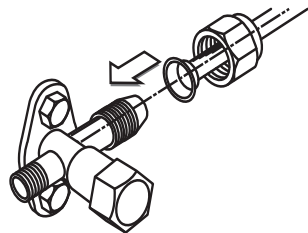

Figure 60: Pipe Attachment.



**Note:**

- Do not thread liquid or gas piping through bracket used to hold main power cables.
- When tightening the flare nut with torque wrench, ensure the direction for tightening follows the arrow on the wrench.

Table 31: Torque Wrench Tightening

Outside Diameter (Inches)	Torque (Lbs.-ft)
1/4	13-18
3/8	24.6-30.4
1/2	39.8-47.7
5/8	45.6-59.3
3/4	71.6-87.5

Figure 61: LSU90-120HEV/HEV1, LSU90-120HXV Outdoor Unit Piping Connection.

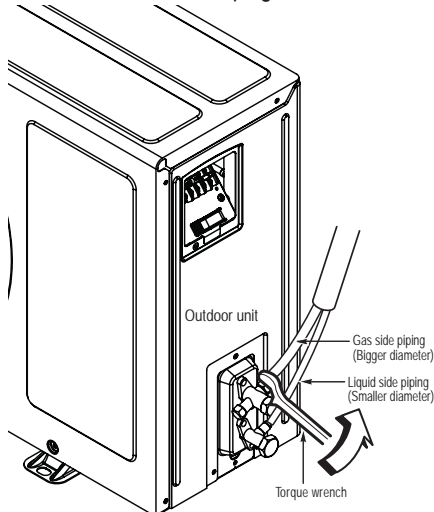

Figure 62: LSU180HEV/HEV1 Outdoor Unit Piping Connection.

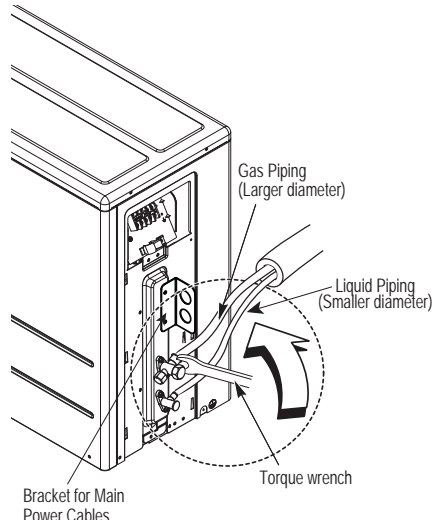
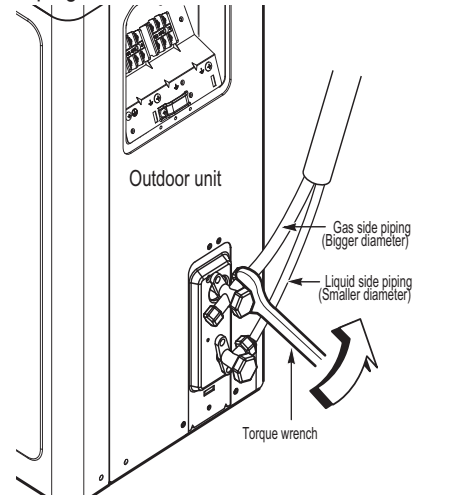

Figure 63: LSU240HEV/HEV1 Outdoor Unit Piping Connection.



# REFRIGERANT PIPING CONNECTIONS

## Indoor Unit Connections

### Piping to Indoor Unit (HSV3, HLV, HXV, HEV, HEV1)

Follow the steps below and refer to the illustrations on this page to connect piping to the Single Zone indoor unit. To see specific bundling of piping and drain hose, see Section, “*Bundling and Cutting Line*” on page 45. Also, refer back to “*Drain Hose Guidelines*” section for proper drainage slope during piping procedure.

1. Pull the screw cap(s) at the bottom of the indoor unit (Figure 64).
2. Unscrew the two (2) or three (3) screws (depending on the indoor unit model) at the bottom of the chassis cover.
3. Remove the chassis cover, being careful not to scratch the main horizontal vane.
4. From the rear of the indoor unit, pull the tubing holder away from the unit as shown in Figure 65.
5. Remove the pipe port cover.
6. Position the tubing by unfolding the tubing and bending the tubing slowly downward first, as shown below.

Figure 64: Removing Chassis Cover from Indoor Unit.

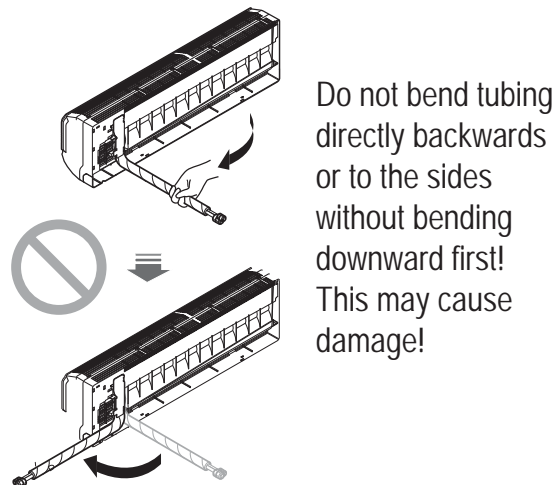
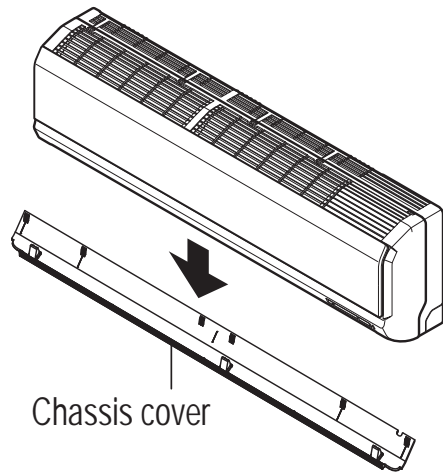
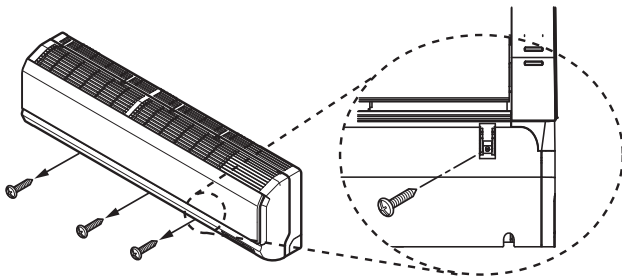

**Note:**  
Bending the tubing directly left or right, without bending downward first, may cause damage.

Figure 65: Bending Pipe Tubing at Rear of Indoor Unit.

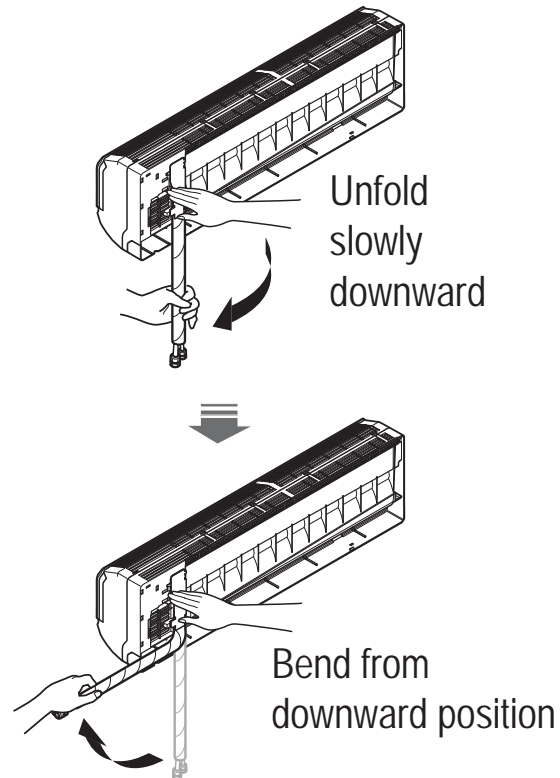

# REFRIGERANT PIPING CONNECTIONS

## Indoor Unit Connections - Conduit Bracket Placement

### Piping to Indoor Unit - Conduit Bracket Placement (HV3, HEV, HEV1)

1. Follow steps 1 through 6 on the previous page to connect piping to the rear of the indoor unit.

Most HV3, HEV, HEV1 and HXV single-zone models require an additional conduit "bracket/nut" to be installed at the rear of the indoor unit to secure an elbow conduit. Follow the steps below for correct placement for your unit model.

2. Set the conduit by using the bracket and "D" screws from the accessory kit. This must be done prior to permanent placement of the piping to the rear of the unit, otherwise you won't be able to reach the conduit once piping and drain hose are in place and anchored.

- For specific bracket placement, see each figure relating to the specific single-zone model.

Figure 70: Elbow Conduit



**Note:**

Pay attention to bracket placement on each single zone units. Your model might be slightly different from figure shown in this manual.

For specific bundling (taping) techniques of the Pipe and Drain Hose, see Section, "Bundling and Cutting Line" on page 45.

Figure 66: Installing Bracket for Conduit (HV3)

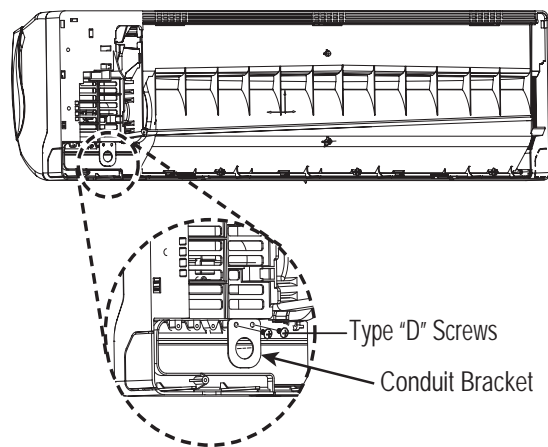

Figure 68: Installing Bracket for Conduit (120HEV)

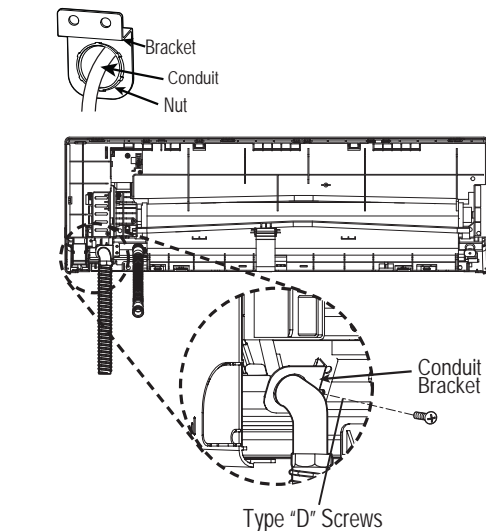

Figure 67: Installing Bracket for Conduit (090HEV, 090HEV1)

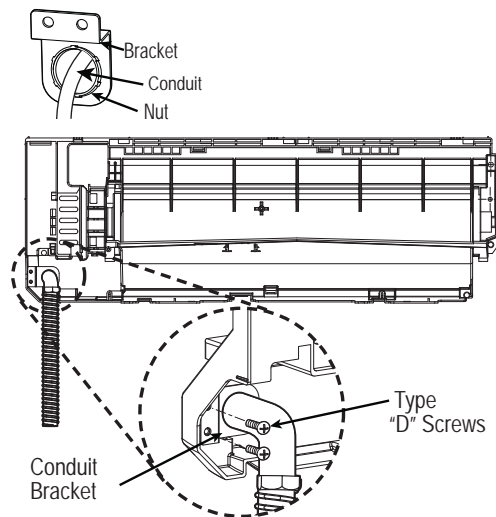
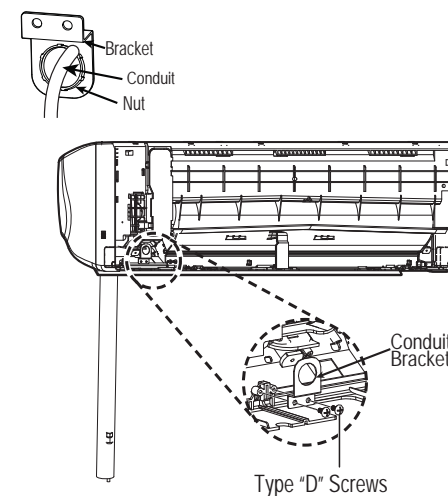

Figure 69: Installing Bracket for Conduit (180HEV, 180HEV1, 240HEV, 240HEV1)



# REFRIGERANT PIPING CONNECTIONS

## Bundling and Cutting Line

Piping and cabling must be insulated and bundled together correctly for safety and usage. Follow proper methods and procedures as outlined here and on the next pages to ensure installation and piping are correctly installed.

As shown in Figure 71, the indoor unit pipe are fully encased in insulation material.

1. Bind together the two pipes, using vinyl tape. Make sure there are no gaps during the binding.
2. Be sure the tube cutting line is placed upward (Figure 72).
3. Verify that rear piping house section is wrapped with vinyl tape.
  - Use a narrow type of vinyl tape for this step.
4. Continue to wrap the Indoor unit pipe as connected to the outdoor connection pipe as shown in Figure 73.

Figure 72: Correct Cutting Line Placement

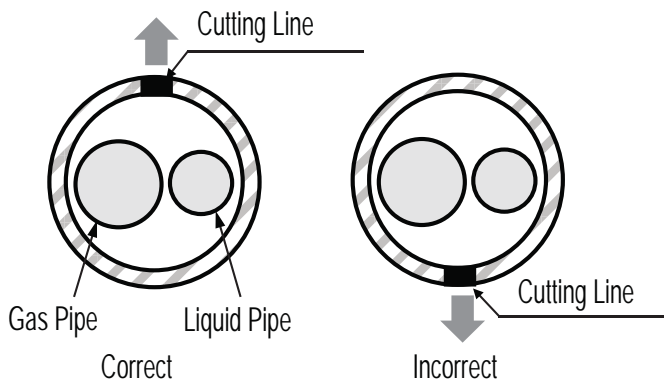

5. Using a wider vinyl tape, bundle the piping and drain hose together (Figure 74).
  - Tape should be sufficient to cover the piping in order to fit into the rear piping housing area at the back of the indoor unit (Figure 75).

Figure 75: Bundling and Placement at Rear of IDU

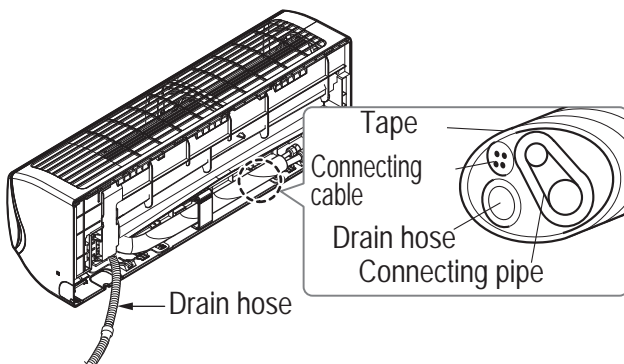

Figure 71: Piping with Insulation Material

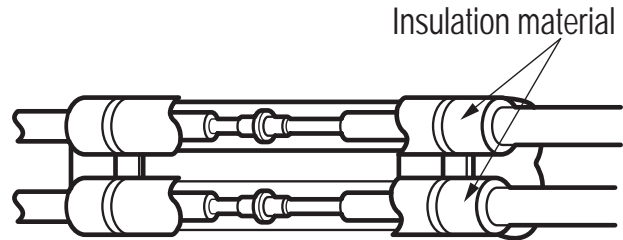

Figure 73: Wrapping Connection Pipe to Indoor Unit's Pipe

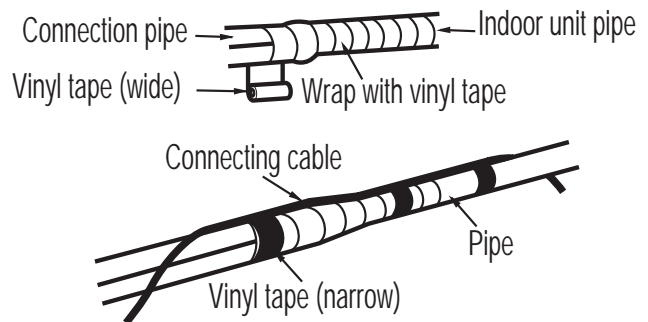
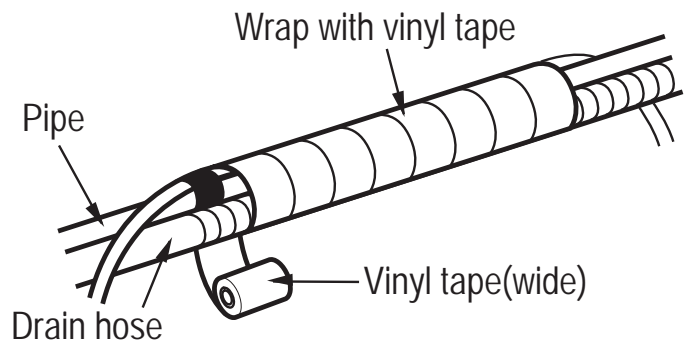

Figure 74: Bundling Pipe and Drain Hose, Rear of IDU



# REFRIGERANT PIPING CONNECTIONS

## Refrigerant Piping Insulation

### Refrigerant Piping System Insulation

All refrigerant piping from the outdoor unit to the indoor units must be insulated correctly for safety and usage. Y-branch connections, header branch connections, refrigerant piping, field-provided isolation ball valves (if present), service valves, and elbows must be properly and completely insulated using closed cell pipe insulation (up to the indoor unit piping connections). To prevent heat loss / heat gain through the refrigerant piping, all refrigerant piping including liquid lines and vapor lines shall be insulated separately. Insulation shall be a minimum 1/2" thick, and thickness may need to be increased based on ambient conditions and local codes. Table on next page lists minimum wall thickness requirements for Ethylene Propylene Diene Methylene (EPDM) insulation.

Inside the outdoor unit, maximum pipe temperature is 248°F and minimum pipe temperature is -40°F. For field insulation of refrigerant piping between outdoor units and indoor units, consider the following pipe temperature ranges for an operating heat pump system:

- Heating mode refrigerant temperature ranges: Liquid 75-118°F; High Pressure Vapor 95-220°F
- Cooling mode refrigerant temperature ranges: Liquid 75-118°F; Low Pressure Vapor 40-90°F

All insulation joints shall be glued with no air gaps. Insulation material shall fit snugly against the refrigeration pipe with no air space between it and the pipe. Insulation passing through pipe hangers, inside conduit, and/or sleeves must not be compressed. Protect insulation inside hangers and supports with a second layer. All pipe insulation exposed to the sun and outdoor elements shall be properly protected with PVC, aluminum vapor barrier, or alternatively placed in a weather-resistant enclosure such as a pipe rack with a top cover; and meet local codes. LG-provided Y-branches are shipped from the factory with pre-formed peel-and-stick foam insulation jackets, with a 1.84 lb./ft.3 density, 1/2" thickness, and meet UL94 MF-1 flammability.

The design engineer should perform calculations to determine if the factory-supplied insulation jackets are sufficient to meet local codes and avoid sweating. Add additional insulation if necessary. Check the fit of the insulation jacket after the header fitting and all run-out pipes are installed. Mark all pipes at the point where the insulation jacket ends. Remove the jacket. Install field provided insulation on the run-out and main trunk pipes first. Install the LG-provided insulation plugs on the ends of all unused header ports. Peel the adhesive glue protector slip from the insulation jacket and install the clam-shell jacket over the fitting.

Figure 76: Typical Pipe Insulation, Power Wire and Communications Cable Arrangement

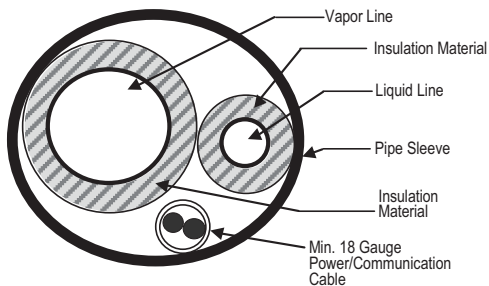

Figure 77: Typical Insulation Butt-Joint at Indoor Unit Casing

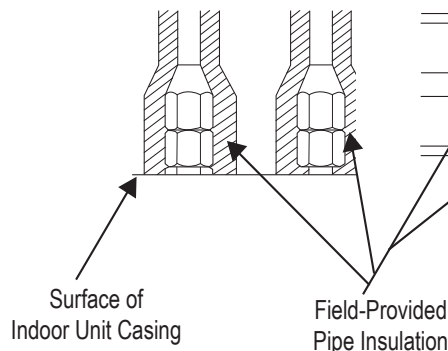
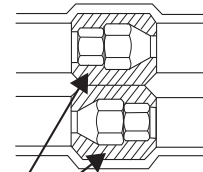

Figure 78: Typical Refrigerant Flare Fitting Insulation Detail



#### Note:

- Do not insulate gas and liquid pipes together as this can result in pipe leakage and malfunction due to extreme temperature fluctuations.
- Be sure to fully insulate the piping connections.

# REFRIGERANT PIPING CONNECTIONS

## Refrigerant Piping Insulation

### Minimum Refrigerant Pipe Ethylene Propylene Diene Methylene (EPDM) Insulation Wall Thickness Requirements

**Note:**

Follow locals codes when selecting EPDM insulation wall thickness.

Table 32: Insulation Guidelines for Typical and Special Circumstances

Classification		Air-conditioned location		Non-air conditioned location	
		1. Typical location	2. Special location	3. Typical location	4. Special location
Liquid pipe	ø1/4 inch	1/2 inch	1/2 inch	1/2 inch	1/2 inch
	ø3/8 inch				
	≥ø1/2 inch				
Vapor pipe	ø3/8 inch	1/2 inch	3/4 inch	3/4 inch	1 inch
	ø1/2 inch				
	ø5/8 inch				
	ø3/4 inch				
	ø7/8 inch				
	ø1 inch				
	ø1-1/8 inches	3/4 inch	1 inch	1 inch	
	ø1-1/4 inches				
	ø1-3/8 inches				
	ø1-1/2 inches				
ø1-3/4 inches					

1. Typical location (Air-conditioned location): When the piping passes through an indoor area where the indoor unit operates.

- Apartment, classroom, office, mall, hospital, etc.

2. Special location (Air-conditioned location):

1. When the location is air conditioned, but there is severe temperature/humidity difference due to high ceilings
  - Church, auditorium, theater, lobby, etc.
2. When the location is air conditioned, but internal temperature/humidity are high
  - Bathroom, swimming pool, locker room, etc.

3. Typical location (Non-Air conditioned location): When the piping passes through an indoor area where the indoor unit does not operate.

- Hallway or a dormitory or school, etc.

4. Special location (Non-Air conditioned location): If conditions 1 and 2 below are present.

1. When the piping passes through an indoor area where the indoor unit does not operate.
2. When the humidity is high and there is no air flow in the location where the piping is installed.
  - The thickness of the above insulation material is based on heat conductivity of 0.61 Btu/in/h/ft<sup>2</sup>/°F.

# REFRIGERANT PIPING CONNECTIONS

## Pipe Sleeves at Penetrations

### Pipe Sleeves at Penetrations

LG requires that all pipe penetrations through walls, floors, and pipes buried underground be properly insulated and routed through an appropriate wall sleeve of sufficient size to prevent compression of refrigerant pipe insulation and free movement of the pipe within the sleeve. Underground refrigerant pipe shall be routed inside a protective sleeve to prevent insulation deterioration.

Figure 79: Pipe Sleeves at Penetrations

Inside wall (concealed)

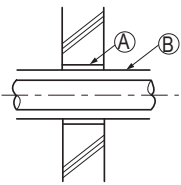

Outside wall

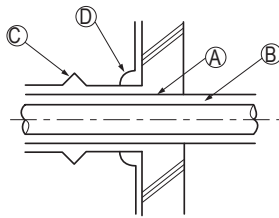

Outside wall (exposed)

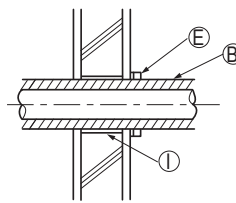

Floor (fire-resistance)

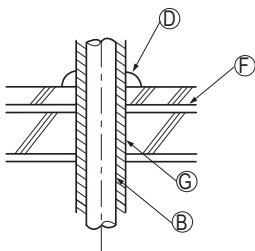

Roof pipe shaft

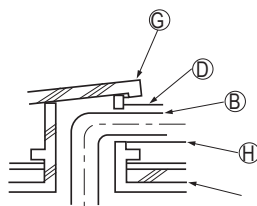

Area between fire-resistant insulation and boundary wall

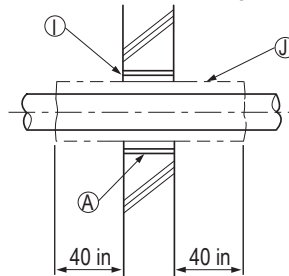

- Ⓐ Sleeve
- Ⓑ Insulation
- Ⓒ Lagging
- Ⓓ Caulk
- Ⓔ Band
- Ⓕ Water-resistant layer
- Ⓖ Sleeve with edge
- Ⓗ Lagging
- Ⓘ Mortar or other fire-resistant caulk
- ⓵ Fire-resistant insulation

When filling an access hole with mortar, cover the area with steel plate so that the insulation will not fall through. For this area, use fire-resistant materials for both the insulation and cover. (Vinyl cover should not be used.)

**Note:**

All floor and wall penetrations should be properly sized and large enough to accommodate pipe diameter plus insulation thickness.



# REFRIGERANT PIPING CONNECTIONS

## Air Purging

### Air Purging Best Practices

Air purging is done to the piping system after all piping has been connected between the indoor and outdoor unit. This step is necessary to be sure that refrigerant can flow through the system without danger of leakage or pressure issues. Air and moisture that is left in the piping can lead to undesirable results and can cause damage to the working unit. It is important to go through a complete air purging cycle to be sure that the lines are cleared out. Note that you may have to repeat this process should any air or moisture be found to remain in the piping. After air purging and evacuating the lines, be sure to take a leak test for all piping and tubing.

#### Note:

Insufficient or incorrectly done air purging may lead to the following:

- Pressure in the system can rise.
- Operating current can rise.
- Cooling or heating efficiency falls.
- Moisture in the refrigerant circuit may freeze and block capillary tubing
- Water can lead to corrosion of parts in the system.

### Air Purging with a Vacuum Pump - Preparation Steps

1. Verify that each set of pipes (liquid and gas) are properly connected between the indoor and outdoor unit.
  2. Remove service valve caps from the gas and liquid valves at the outdoor unit (Figure 80).
  3. Both the liquid and gas side service valves at the outdoor unit should be kept closed at this step.
  4. Set up the purging, hose connections by referring to Figure 81.
  5. Do a Leak Test, by proceeding to Soap Water Method - Leak Testing section on next page.
- Successful leak testing must be performed before Evacuation can begin.
6. Go to *Evacuation* section, on page 51 to complete the purging process.

#### Note:

- Be sure to use a manifold valve for air purging. If it is not available, use a stop valve for this purpose.
- Be sure that the knob of the three-way valve is always kept close.

Table 33: Evacuation Table

Evacuation Table*	
Tubing = Less than 33 ft.	Tubing = More than 33 ft.
10 minutes or more	15 minutes or more

\* Required time for evacuation when 30 gal/h vacuum pump is used.

Figure 80: Removing Service Valve Caps - Outdoor Unit (appearance may be different depending on model)

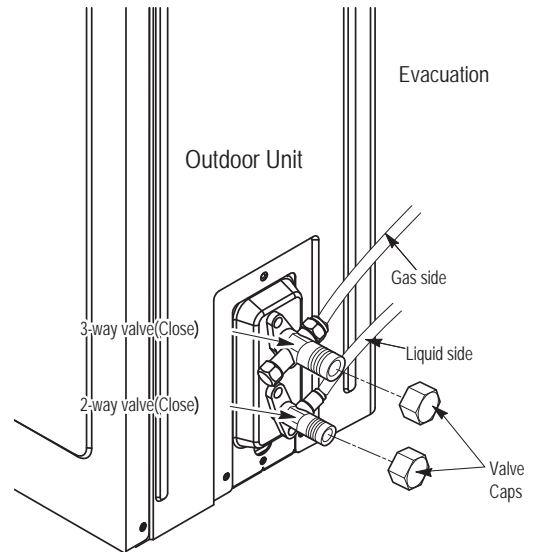
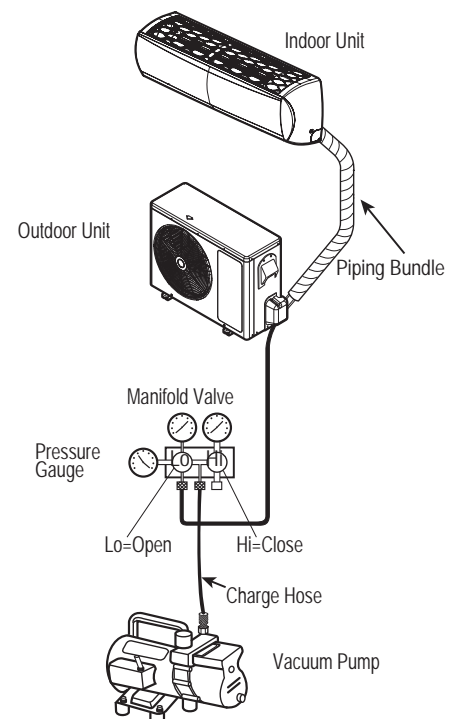

Figure 81: Evacuation Setup  
Air Purging / Evacuation Setup



# REFRIGERANT PIPING CONNECTIONS

## Leak Test/Soap Method Check

### Leak Test

#### Note:

Perform the leak test by pressurizing nitrogen gas to 550 psi on both the liquid and gas pipes. Test with the piping service valves closed. If the pressure does not drop for twenty-four (24) hours, the system passes the test. If the pressure drops, there is a nitrogen leak in the system. Find the leak, repair, and then test again.

#### Pressure Gauge Hookup

1. Connect the manifold valve (which includes the pressure gauges), along with dry nitrogen gas cylinder to the service valves using charge hose (Figure 82).
2. Pressurize the system to maximum 550 psig with dry nitrogen gas and close the cylinder valve when the gauge reading reaches 550 psig.

#### **⚠ DANGER**

Use of combustible gases including oxygen, may result in fire or explosion. There is risk of physical injury or death.

#### **⚠ WARNING**

Use of combustible gases including oxygen runs the risk of fire and explosion. Inert gas (nitrogen) should be used when checking plumbing leaks, cleaning or repairs of pipes, etc. There is risk of physical injury or death.

#### Note:

- To avoid nitrogen entering the refrigerant system in a liquid state, the top of the cylinder must be higher than its bottom when you pressurize the system.
- Be sure cylinder is used in a vertical standing position.

#### Soap Water Method - Leak Testing

1. Remove the caps from the 2-way and 3-way valves. See Figure 80.
2. To open the 2-way valve turn the valve stem counter-clockwise approximately 90°, wait for about 2~3 sec, and close it.
3. While running the nitrogen gas tank hookup, apply a soap water or a liquid neutral detergent on the indoor unit connection or outdoor unit connections by using a soft brush.
4. While running the pressure gauge system, observe the connections for any leakage.
  - If you see bubbles appearing at any of the connection points/joints (at either inside and outside units), it is an indication of a leak.
5. Make a note of where the leaks are coming from along the liquid and gas piping.
6. Disengage the nitrogen pressure by loosening the charge hose connector at the nitrogen cylinder (Figure 82 above).
7. Once system pressure is reduced back to normal range, disconnect hose from the cylinder.
8. At this point you will need to make all repairs to connections and piping where bubbles were observed.
9. Once all repairs are made, repeat soap testing using nitrogen cylinder and check for any further leaks.
10. Once system is leak free, proceed to Evacuation steps.

Figure 82: Leak Test Diagram.

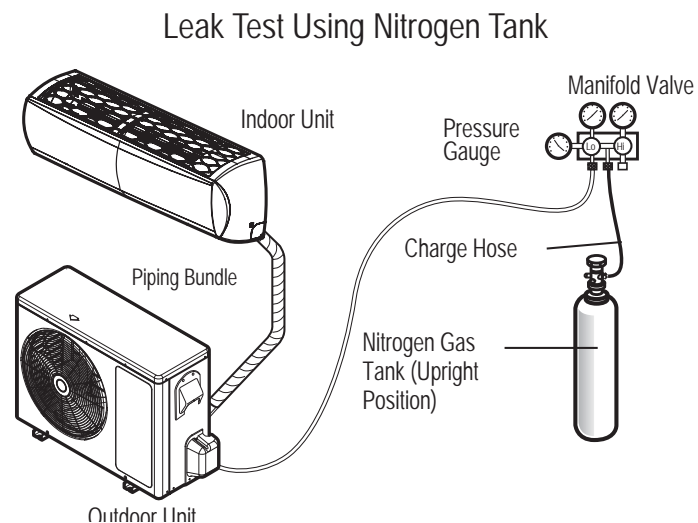

#### Leak Test Ambient Temperature Correction

If the ambient temperature changed between the time when pressure was applied and when the pressure drop was checked, adjust results by factoring in approximately 1.45 psi for each 2°F of temperature difference.

Correction formula = (Ambient temperature when pressure was applied - Ambient temperature when pressure drop was checked) x 0.01.

Example:

When pressure (550 psig) was applied, the ambient temperature was 80.6°F; 24 hours later when pressure drop (540 psi) was checked, ambient temperature was 68°F.

Thus,  $80.6 - 68 \times 0.01 = 0.126$ . In this case, the pressure drop of 0.126 was due to temperature difference, therefore, there is no leak in the refrigerant piping system.

# REFRIGERANT PIPING CONNECTIONS

## Evacuation of Lines Finishing Up

### Evacuation

After successful leak testing has been performed, follow Evacuation procedure. Follow the same steps for charge hose hookup to the system. See Figure 82 on previous page for proper hookup.

#### Procedure

1. Confirm that the “Lo” knob of the manifold valve is open. Refer back to Figure 82.
2. Confirm that the “Hi” knob of the manifold valve is left closed.
3. Run the Vacuum pump.
  - Operate pump until the system has been evacuated down to 300 microns.
  - Run pump an additional 15 minutes after reaching micron level.

The duration of the operation of the vacuum pump will vary according to pipe length and the capacity of the pump. Refer to Table 33 for accurate time duration.

### Finishing the Job

Once the Evacuation procedure has been performed, follow the steps below to turn off all valves at the outdoor unit and safely disengage the manifold valve, along with the vacuum pump. Refer back to the illustrations and tables on the previous pages as you go through the steps below.

#### Procedure

1. Using a wrench, turn the valve of the liquid stem counter-clockwise to fully open the valve (refer back to Figure 80).
2. Turn the valve of the gas stem counter-clockwise to fully open the valve.
3. Loosen the charge hose connected to the gas side service port slightly to release the pressure, and then remove the hose.
4. Replace the flare nut and its cap on the gas service port and fasten the flare nut securely using an adjustable wrench.
  - This process is very important to prevent leakage from the system.
5. Replace the valve caps at both gas and liquid side service valves and then fasten them tightly.
  - Once done, this will complete the air purging process with a vacuum pump.

4. Turn off the pump and leave the connections secured to the two service valves.
5. Wait 5 minutes.
6. If the system fails to hold 500 microns or less, check all connections for tight fit and repeat the evacuation procedure.
7. Once, desired vacuum is reached, close the “Lo” knob of the manifold valve and stop the vacuum pump.
8. Proceed to *Finishing the Job* section, below.

### Test Run

After leakage testing, and evacuation procedure the system should be ready to start up for a test run. Follow the guidelines below for proper procedure.

- Check that all tubing, piping and wiring are properly connected.
- Make sure that the gas and liquid service valves are fully open.
- Start up the system and do a test run.
- As system is up and running verify all is in working order and make notes as needed to work around any issues that might crop up.

### Installing Batteries into Remote Controller

As part of the test run, you will need to insert batteries and power on the remote controller. To insert the batteries follow the steps below. For information on using the remote controller, refer to its owner’s manual.

#### Procedure

1. The remote controller needs two AAA (1.5V) batteries for operation. Remove the battery cover from the back of the remote controller (Figure 83).
  - Push downward on the tab at the top of the battery cover and then lift up to remove.
2. Insert the two new batteries.
  - Align batteries by the (+) and (-) sides.
  - The interior battery compartment of the remote controller will have clear markings for the (+) and (-) placement.
3. Verify that the batteries have “clicked” into the compartment and are firmly engaged with the contacts on either side of them.
4. Reattach the back cover of the remote controller.
5. Proceed with powering on the remote controller and usage as needed.

Figure 83: Remote Controller - Installing Batteries  
Single Zone Remote Controller - Rear View

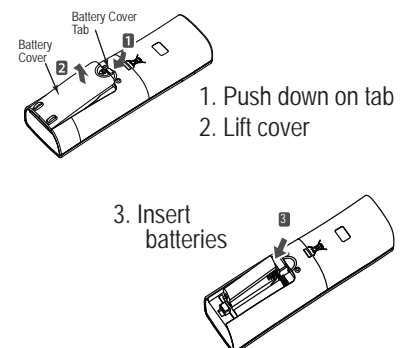

# REFRIGERANT PIPING CONNECTIONS

## Pump Down, Cooling Only Mode

### **⚠ WARNING**

⊘ Never air purge with refrigerant as it can lead to refrigerant leakage which can cause bodily harm and injury, especially if inhaled.

### **Note:**

Use a vacuum pump that can evacuate down to 500 microns.

1. If moisture remains in the piping after the system is evacuated for two (2) hours, break the vacuum (down to 7.5 psi with nitrogen gas).
2. Evacuate the system again with the vacuum pump for at least one (1) hour to 500 microns
3. If the system does not reach 500 microns within two (2) hours, repeat the vacuum break and evacuation procedure until the gauge does not rise.

## Pump Down Procedure

This procedure is performed when a unit has to be relocated or the refrigerant circuit is serviced. "Pumping down" is a term used to mean collecting all refrigerant into the outdoor unit without the loss of any refrigerant. Follow the procedure and guidelines below to safely collect refrigerant back into the outdoor unit. Always adhere to and be familiar with local codes regarding the handling of refrigerant.

The system must be placed in Cooling mode in order to proceed with the pump down procedure. If needed, refer to the sections below for proper steps to place the unit into Cooling Mode.

1. Connect a low-pressure gauge with manifold hose to the charge port on the gas line service valve.
2. Open the gas line service valve halfway.
3. Purge the air in the manifold hose using the refrigerant.
4. Close the liquid line service valve all the way.
5. Turn on the unit's power switch and start the cooling mode operation.
6. Observe the pressure gauge reading. When it gets to 1 to 0.5 kg/cm<sup>2</sup> (14.2 to 7.1 psig), fully close the gas line valve and then immediately turn the unit off.

• Pump down procedure is complete at this time and all refrigerant should be collected into the outdoor unit.

### **⚠ WARNING**

Never inhale or handle refrigerant directly. Doing so may cause bodily harm and injury.

### **Note:**

Perform Pump Down procedure only in the cooling mode.

## Enabling Cooling Only Mode

Before running the Pump Down procedure, you must place the unit into Cooling Only Mode. In order to be able to run Cooling Only Mode, you must enter the unit into the Installer Mode by pressing the Reset button and the JET MODE button simultaneously.

1. Shut down power to system completely.
  2. Enter the Installer Mode as stated in the paragraph above.
  3. Set code to 45.
  4. Press Power-ON button and select the code number 45.
- Unit should beep to acknowledge that code has been received.
5. Turn off power.
  6. Turn power back on to system.

### **Note:**

- Once the system is in Installer Mode (with Cooling Only Mode initiated), automatic operation is suspended.
- Once Cooling Only Mode is disabled, the unit will return to normal operation.
- Installer Code cannot be entered if the unit is running. The system must be completely powered off.
- All Installer Code numbers must be entered into the system during Power Off state. (Complete shutdown of the system.)
- WLAN Module's communication time will lag by about 1 minute after unit is turned back on, and in normal operating mode.
- Entire lock or Mode lock cannot be set if you set heating or automatic operation through the central controller.

## Disabling Cooling Only Mode

After Pump Down procedure has been performed, you will need to disable Cooling Only Mode, and place the unit back into normal operating mode. Follow the procedure below.

1. Shut down power to system completely.
  2. Enter the Installer Mode.
  3. Set code to 46.
  4. Press Power-ON button and select the code number 46.
- Unit should beep to acknowledge that code has been received.
5. Turn off power.
  6. Turn power back on to system.

# ELECTRICAL WIRING

## General Information and Safety Guidelines

### **⚠ WARNING**

- All power wiring and communication cable installation must be performed by authorized service providers working in accordance with local, state, and National Electrical Code regulations related to electrical equipment and wiring, and following the instructions in this manual.
- Undersized wiring may lead to unacceptable voltage at the unit and may cause a fire hazard, physical injury or death.
- Properly ground the Single Zone outdoor and indoor units. Ground wiring is required to prevent accidental electrical shock during current leakage.
- Ground wiring must always be installed by a qualified technician.
- ⓧ Do not connect ground wire to refrigerant, gas, or water piping; to lightning rods; to telephone ground wiring; or to the building plumbing system. Failure to properly provide a National Electrical Code-approved earth ground can result in electric shock, physical injury or death.
- Install appropriately sized breakers / fuses / overcurrent protection switches and wiring in accordance with local, state, and National Electrical Code regulations related to electrical equipment and wiring, and following the instructions in this manual. Using an oversized breaker or fuse may result in electric shock, physical injury or death.

### **Note:**

- Consider ambient conditions (temperature, direct sunlight, inclement weather, etc.) when selecting, installing, and connecting the power wiring.
- Properly ground the Single Zone outdoor and indoor unit. Improperly ground wire can cause communication problems from electrical noise, and motor current leakage. Ground wiring must always be installed by a qualified technician.
- If the system operates in reversed phase, it may damage the compressors and other components.
- If there is a possibility of reversed phase, phase loss, momentary blackout, or the power goes on and off while the system is operating, install a field-supplied phase loss protection circuit.
- ⓧ Do not connect ground wire to refrigerant, gas, or water piping; to lightning rods; to telephone ground wiring; or to the building plumbing system. Failure to properly provide a National Electrical Code-approved earth ground can result in property damage and equipment malfunction.
- Install appropriately sized breakers / fuses / overcurrent protection switches and wiring in accordance with local, state, and National Electrical Code regulations related to electrical equipment and wiring, and following the instructions in this manual. Using an oversized breaker or fuse may result in equipment malfunction and property damage.
- Undersized wiring may lead to unacceptable voltage at the unit and may cause unit malfunction.

## Power Supply / Power Wiring Specifications

### **Note:**

- Single Zone systems operate at 1Ø, 208-230V, 60Hz, with the exception of Mega 115V, which operates at 1Ø, 115V, 60Hz.
- Power supply, wire type and size should be selected based on National Electrical Code and local codes. Maximum allowable voltage fluctuation  $\pm 10\%$  or nameplate rated value.
- Properly ground the Single Zone outdoor unit and indoor unit per National Electrical Code and local codes.
- For power to the outdoor unit, use copper wiring that is solid or stranded that complies with all local and national electrical codes.
- Ground wire should be longer than the common power/communication wires.
- Refer to the inside of the Chassis Cover for Circuit and Terminal Block Diagrams for your model unit.
- Always match color codes of each wire and follow wiring diagram.

# ELECTRICAL WIRING

## Power Wiring Specifications and Best Practices

### Connecting the Power Wiring Guidelines

Best practice dictates using ring or spade terminals to terminate power wiring at the power terminal block (Figure 85).

If ring terminals or spade clips are not available, then:

**⚠ WARNING**

⊘ Do not terminate different gauge wires to the power terminal block. Slack in the wiring may generate heat and fire.

**Note:**

- When terminating wires of the same thickness, follow the instructions demonstrated in the illustrations below at Figure 86.
- Firmly attach the wire; secure in a way to prevent external forces from being imparted on the terminal block.
- Use an appropriately sized screwdriver for tightening the terminals.
- ⊘ Do not over tighten the connections; overtightening may damage the terminals.

Figure 85: Close up of a Typical Ring Terminal

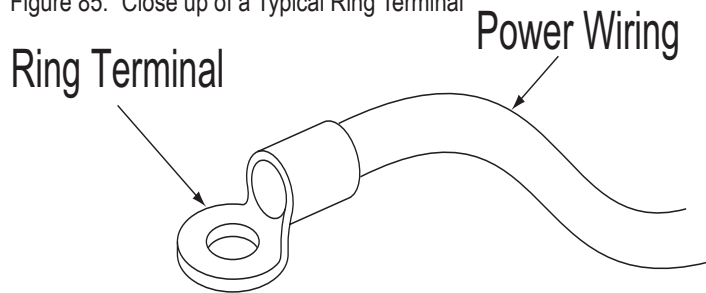
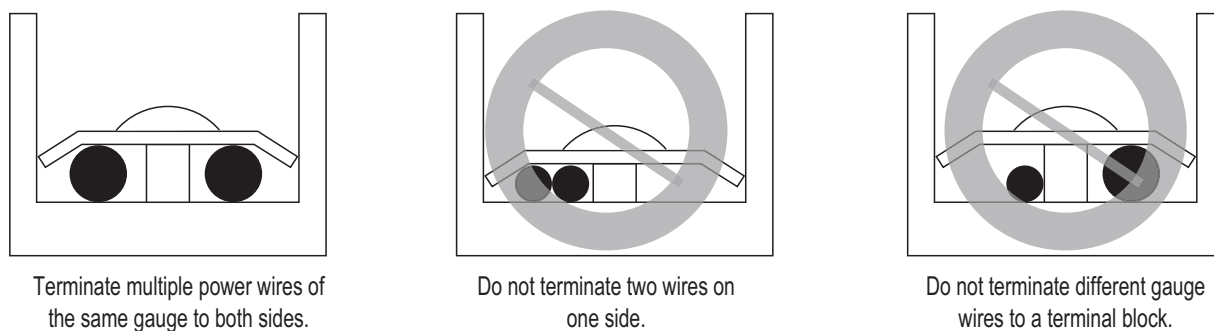

Figure 86: Proper and Improper Power Wiring Connections



**⚠ WARNING**

- If power wires are not properly terminated and firmly attached, there is risk of fire, electric shock, and physical injury or death.
- ⊘ Never ground the shield of the communications cable to the indoor unit frame or other grounded entities of the building.

**Note:**

- ⊘ Never apply line voltage power to the communications cable terminal block. If contact is made, the PCBs may be damaged.
- Always include some allowance in the wiring length when terminating. Provide some slack to facilitate removing the electrical panels while servicing.

Figure 84: Single Zone Outdoor and Indoor Wiring and Communications Cable Diagram

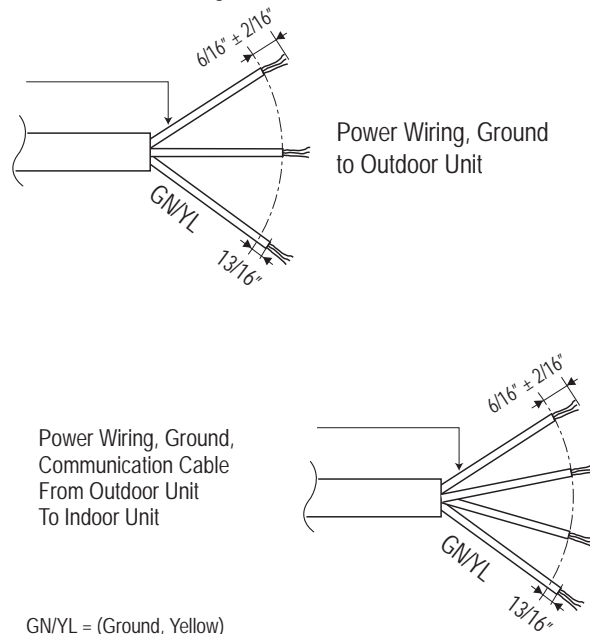

GN/YL = (Ground, Yellow)

# ELECTRICAL WIRING

## Power Wiring Specifications and Best Practices

### General Communication Cable Specifications

- For power / communication wires between the Single Zone outdoor unit and the indoor unit, use a four (4) conductor, stranded, shielded or unshielded wire. If shielded, the wire must be grounded to the chassis at the outdoor unit only.
- Minimum 18 gauge CVVS or CPEVS cable.
- Insulation material as required by local code.
- Rated for continuous exposure of temperatures up to 140°F.
- Maximum allowable cable length: 984 feet.
- Firmly attach the cable; provide slack but secure in a way to prevent external forces from being imparted on the terminal block.
- Wiring should be completed without splices.

**Note:**

- Always verify the communication cable is connected to a communications terminal on the Single Zone unit. Ⓣ Never apply line voltage power to the communication cable connection. If contact is made, the PCBs may be damaged.
- The shield of the communications cable connecting the outdoor unit to the indoor unit should be grounded only to the outdoor unit frame.
- Tie the shield of each cable segment together using a wire nut at the indoor unit. Maintain polarity throughout the communication network.
- Position the incoming power to the outdoor unit away from the power / communications cables from the outdoor unit to the indoor unit.
- Ⓣ Never use a common multiple-core communications cable. Each communications bus shall be provided a separate cable (i.e., between outdoor unit and indoor unit).

### Communication Cables Between the Single Zone Unit and the Controller

- Simple Controllers: field-provided, 18 gauge, stranded four-conductor communication cable (shielded).
- All other Central Controllers: field-provided, 18 gauge, stranded two-conductor communication cable (shielded).
- Insulation material as recommended by local code.
- Connect all central control devices such as ACP, BACnet® and LonWorks® gateways, and energy recovery ventilators all on the same cable. Order does not matter. Polarity does. Keep “A” terminals with “A” terminals, and “B” terminals with “B” terminals.
- Starting at the outdoor unit, terminate the cable on terminals Internet A and Internet B. Route the cable as needed between each device.

### Controller Options

Refer to Table 34 as to which remote controller models to use for each Single Zone model types. Once all wiring is connected to the indoor and outdoor units be sure to test the accompanying remote controllers for performance. As always, follow all safety warnings and notes when operating the Single Zone units using the remote controller.

Additionally, most of the Single Zone High Efficiency and Extended Pipe outdoor models can use the following controllers when accompanied with the PI 485 VNet Accessory:

- AC Smart
- ACP
- BACnet™
- LonWorks™
- LGMV

Mega 115V is compatible with the following controllers:

- PREMTB10U
- PQDSB1
- PZCWR5C1

**Note:**

- LS091HSV3, LS121HSV3 models cannot use PI-485, or the controller accessories.
- Single Zone Mega and Mega 115V systems cannot use PI-485, or the controller accessories mentioned on this page. They can use LGMV.
- BACnet™ is a trademark of ASHRAE; LonWorks™ is a trademark of Echelon Corporation.

Table 34: Single Zone Models and Associated Remote Controller Model

Single Zone Model Type	Remote Controller Model
LS091HSV3, LS121HSV3	AKB73855712
LS181HSV3	AKB73855712
LS240HSV3	AKB73855713
LS307HV3, LS360HV3	AKB73855713
<b>Single Zone Extended Pipe System</b>	
LS240HLV, LS300HLV, LS360HLV	AKB74055401
<b>Single Zone Mega System (HEV)</b>	
LS090HEV, LS120HEV	AKB73835305
LS180HEV, LS240HEV	AKB73835305
<b>Single Zone Mega System (HEV1)</b>	
LS090HEV1, LS120HEV1	AKB73835318
LS180HEV1, LS240HEV1	AKB73835318
<b>Single Zone Mega 115V System</b>	
LS090HXV, LS120HXV	AKB73456121



# ELECTRICAL WIRING

## Indoor Unit Electrical Connections

### Overview - Connecting Indoor Unit Electrical Wiring

The general guidelines for connecting electrical and communication cables to the indoor unit are the same for each of the Single Zone Wall Mounted indoor units, however, the actual connections on the terminal block will differ. See each illustration for the Single Zone unit model that you are wiring for correct contact on each terminal block. Depending on your indoor unit, the location of the terminal block on the indoor unit might vary slightly from the images shown in this section.

#### ⚠ WARNING

- Be sure that main power to the unit is completely off before proceeding with these steps.
- Follow all safety and warning information outlined at the beginning and throughout this manual. Failure to do so may cause bodily injury.

#### Note:

- Follow all safety and warning information outlined at the beginning and throughout this manual. Failure to do so may cause unit failure.
- Some units might require you to remove the Control Cover from the terminal block area. Most Control Covers are attached with a phillips screw head.
- Connect the electrical cable to the indoor unit by connecting the wires to the terminals on the control board individually according to the outdoor unit connection. Be sure that the color of the wires at the outdoor unit along with the terminal numbers are the same as those for the indoor unit.

#### Procedure

#### ⚠ WARNING

Be sure there is no power going through the Single Zone system before proceeding with these connections as there be a risk of electrical shock and bodily injury.

1. At the bottom panel of the indoor unit, unsnap the latches which cover the phillips screw heads as shown in Figure 87.
- Normally, there are three (3) screws on the panel, however your indoor unit model may differ.
2. Using a phillips head screwdriver, remove the screws from the bottom panel of the indoor unit and set aside (Figure 88).
3. Remove the bottom panel (Figure 89).
- Removal is necessary to gain access to the terminal block which is situated at the bottom of most indoor units.
- Note that the electrical/communications wiring is usually routed through the back/bottom of the indoor unit (through a knockout panel) as shown on the next page (Figure 90).
4. Using a screwdriver, connect the wires as shown on the next page (Figure 91).
- Each wire should be securely attached to the terminal block.
- Pay attention to the location/connection of the green/yellow ground cable.

Figure 87: Latch over Screws on Bottom Panel, Indoor Unit



Figure 88: Remove Screws from Bottom Panel



Figure 89: Remove (and Reattachment) Bottom Panel





# ELECTRICAL WIRING

## Indoor Unit Electrical Connections

### Connecting Indoor Unit Electrical Wiring - Continued

- When done, reattach the bottom panel to the indoor unit, being careful to align panel using the rear tabs.
  - You might need to give the panel a gentle tap with the palm of your hand to be sure it engages at the bottom.
- Using a phillips screwdriver, reattach the screws to the bottom panel and secure.
- Once screws are in place, re-snap the latches over the screws.
  - Refer back to Figure 87 as an example.
- If all other piping and electrical wiring to the outside unit has been completed at this stage, you can turn the system on to test.
  - If you have not completed the piping connections, ⚡ do not turn power on at this time and proceed to complete all other piping, (along with drain hose) and wiring to the system.

Figure 90: Indoor Unit Knockout (Communication Wires)



Figure 91: Indoor Unit Terminal Block with Grounding Cable (Example Only)

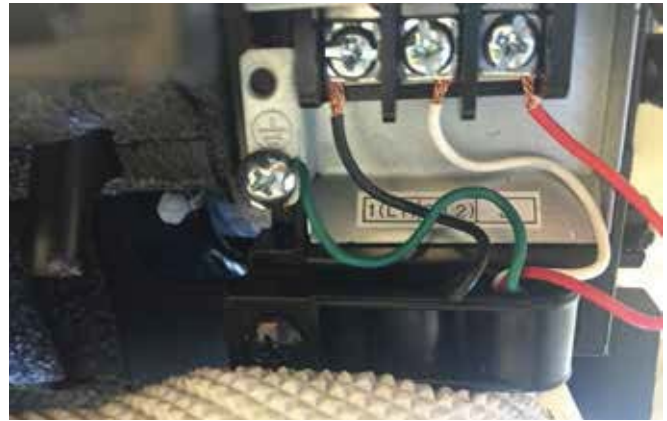

### Terminal Block Connection for HLV

See Figure 92 for specific terminal block wiring for all following Single Zone models:

LSN240HLV

LSN300HLV

LSN360HLV

Figure 92: HLV Indoor Units - Terminal Block Connections

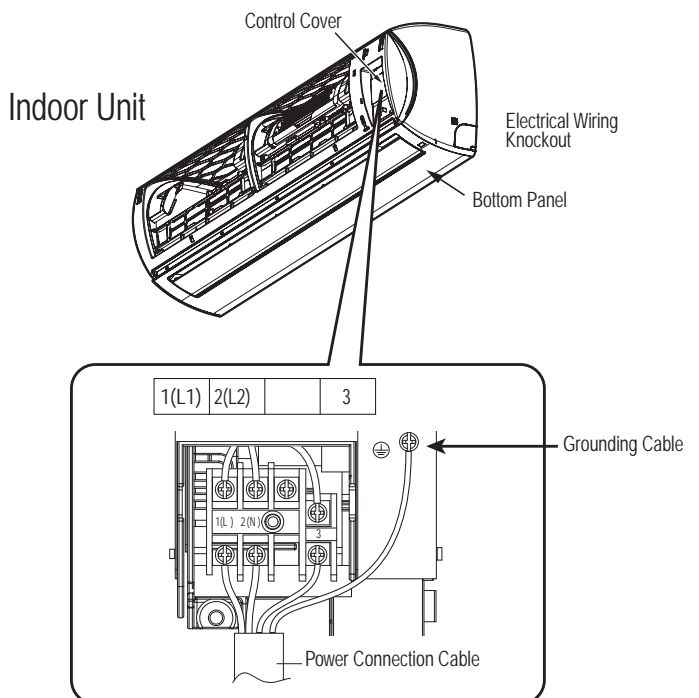

# ELECTRICAL WIRING

## Indoor Unit Electrical Connections

### Terminal Block Connection for HV3

See Figure 93 for specific terminal block wiring for all following Single Zone models:  
 LSN307HV3  
 LSN360HV3

### Terminal Block Connection for 240HSV3

See Figure 93 for 240HSV3 Single Zone terminal block connection. The connections are also identical for LSN307HV3 and LSN360HV3 Single Zone models.

Figure 93: HV3 and 240HSV3 Indoor Units - Terminal Block Connections

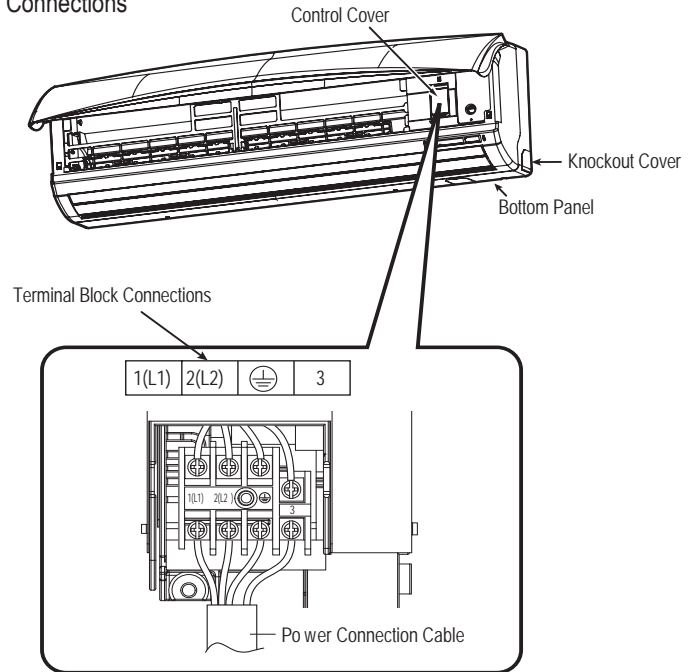

Figure 94: 091HSV3, 121HSV3, 181HSV3 Indoor Units - Terminal Block Connections

### Terminal Block Connection for 091HSV3, 121HSV3, 181HSV3

See Figure 94 for specific terminal block wiring for all following Single Zone models:  
 LSN091HSV3  
 LSN121HSV3  
 LSN181HSV3

**Note:**

- Pay special attention to the location of the grounding cable and the cable restrainer around the other electrical/communication cables when connecting.
- Note that the terminal block is located behind the drain hose and bundled piping on these units.

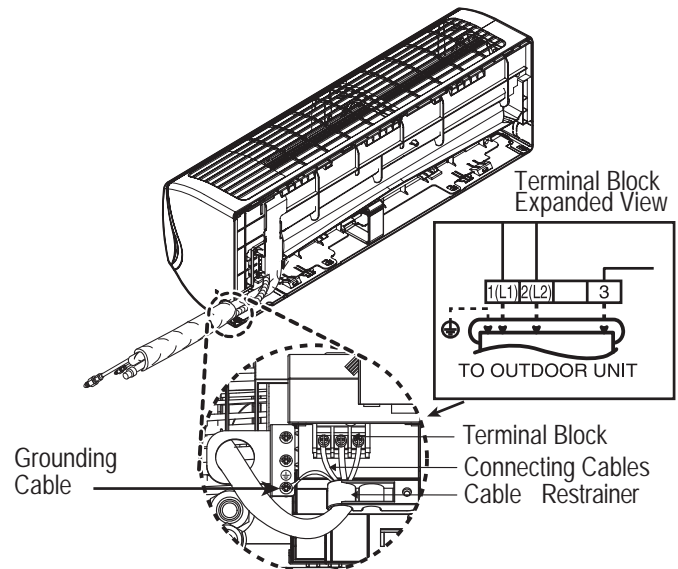

# ELECTRICAL WIRING

## Indoor Unit Electrical Connections

### Terminal Block Connection for Mega 090HEV, 090HEV1, 120HEV, 180HEV, 240HEV

See Figure 95 for specific terminal block wiring for the following Single Zone models:

LSN090HEV  
LSN090HEV1  
LSN120HEV  
LSN180HEV  
LSN240HEV

Figure 95: Mega 090HEV, 090HEV1, 120HEV, 180HEV, 240HEV Indoor Units - Terminal Block Connections

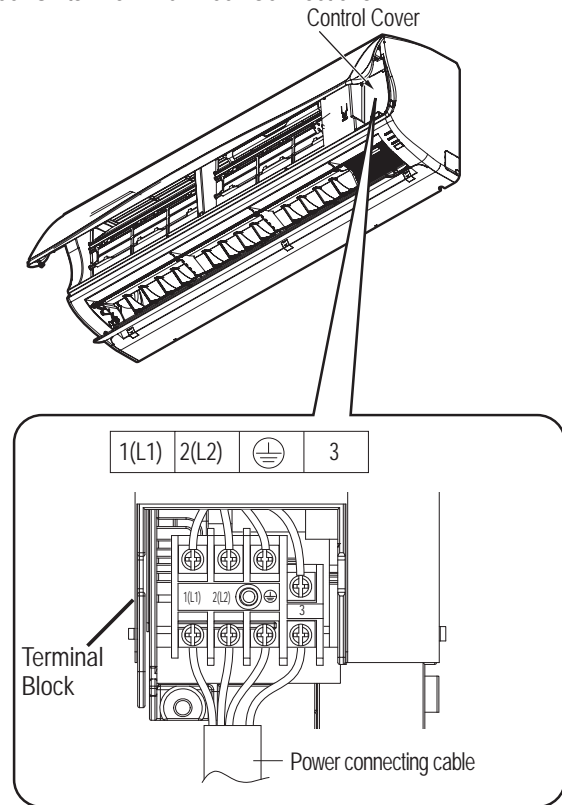

### Terminal Block Connection for Mega 120HEV1

See Figure 96 for specific terminal block wiring for the following Single Zone models:

LSN120HEV1

Figure 96: Mega 120HEV1 Indoor Units - Terminal Block Connections

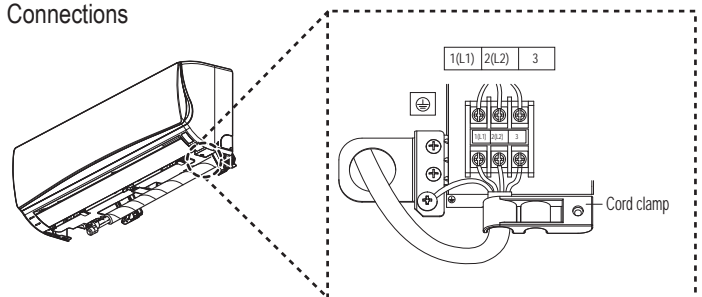

# ELECTRICAL WIRING

## Indoor Unit Electrical Connections

### Terminal Block Connection for Mega 180HEV1, 240HEV1

See Figure 97 for specific terminal block wiring for the following Single Zone models:

- LSN180HEV1
- LSN240HEV1

Figure 97: Mega 180HEV1, 240HEV1 Indoor Units - Terminal Block Connections

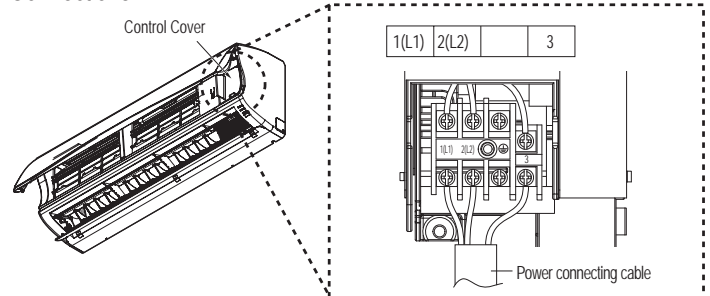

### Terminal Block Connection for Mega 115V 090HXV, 120HXV

See Figure 98 for specific terminal block wiring for all following Single Zone models:

- LSN090HXV
- LSN120HXV

Figure 98: Mega 115V 090HXV, 120HXV Indoor Units - Terminal Block Connections

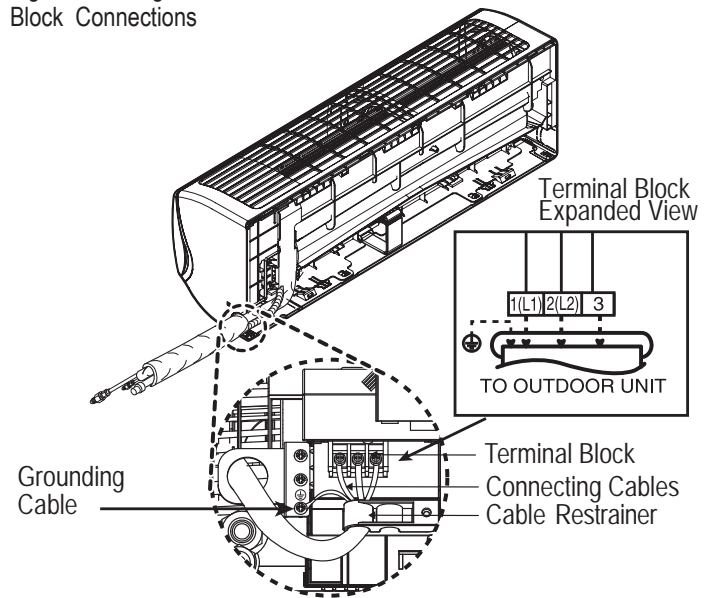

# ELECTRICAL WIRING

## Outdoor Unit Electrical Connections

### Connecting Outdoor Unit Electrical Wiring

The general guidelines for connecting electrical and communication cables to the outdoor unit are the same for each of the Single Zone Wall Mount units, however, the actual connections on the terminal block will differ. See each illustration for the Single Zone unit model that you are installing for correct wiring of each terminal block.

#### ⚠ WARNING

- Be sure that main power to the unit is completely off before proceeding with these steps. Follow all safety and warning information outlined at the beginning of this manual. Failure to do so may cause bodily injury.
- Be sure that a circuit breaker or some other emergency power cutoff device is in place before any power wiring is done to the system. Failure to do so, may cause bodily injury or death.
- ⚡ Never touch any power lines or live cables before all power is cutoff to the system. To do so, may cause bodily injury or death.

#### Procedure

Refer to Figure 99 for an example of how a circuit breaker should be wired through to the Single Zone system.

#### ⚠ WARNING

- Be sure there is no power going through the Single Zone system before proceeding with these connections as it may result in electric shock.
- Familiarize yourself with the location of the circuit breaker and be sure that all power is cut to the Single Zone unit as it may result in electric shock.

1. Using a phillips head screwdriver, remove the conduit panel cover from the outside unit.
2. Before proceeding, inspect all wiring inside the casing to be sure they are secure and have not come loose during transportation and installation of the outdoor unit.
- Loose wires can cause the wiring to burn out quickly.
- Inspect wires for any damage or cracks (manufacturing defects).
3. Confirm that electrical power supply capacity is sufficient to run the unit. See specifications sheets at the beginning of this installation manual for details on power.
4. Confirm that you are using the right gauge size for wiring to proceed.
5. Using a screwdriver, connect the wires as shown in Figure 100.

- Figure 100 shows the connections for the HLV models, however the basic connection procedure is the same for all models. Use this diagram as a general reference on connecting the power cables.
- Each wire should be securely attached to the terminal block.
- Bundle the cabling by using a cable restrainer.
- Pay attention to the location/connection of the green/yellow grounding cable; as in some models the connection may be located to the side of the actual terminal block.
- Maintain a minimum of .2" of wire length from terminal block to cable bundle.

Figure 99: Circuit Breaker Main Power Source

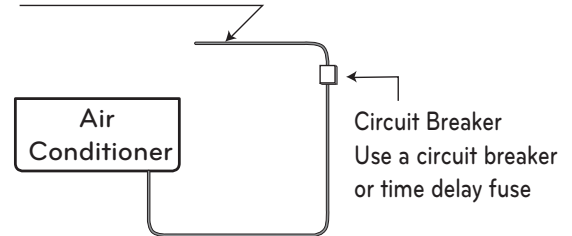
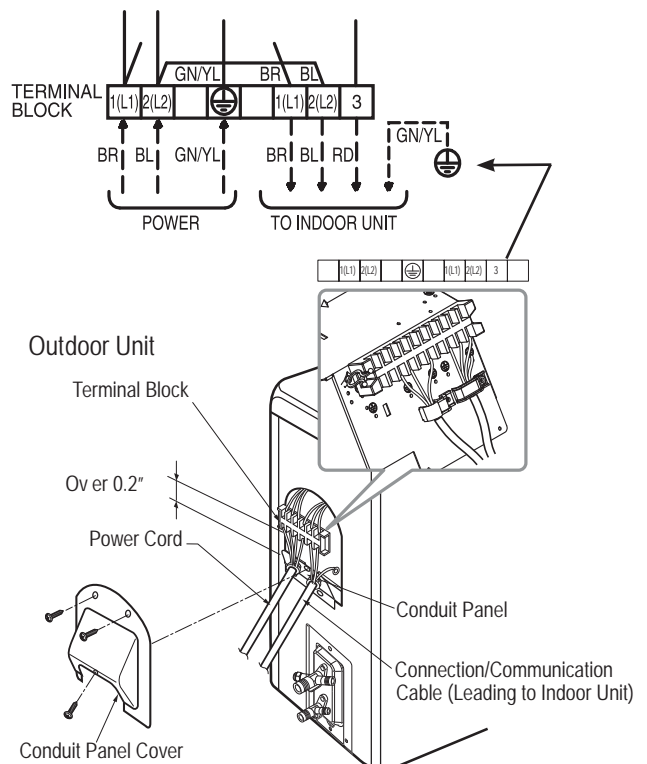

Figure 100: HLV Outdoor Unit - Electrical Connections



### Terminal Block Connection for HLV

See Figure 100 for specific terminal block wiring for all following Single Zone outdoor unit models:

- LSN240HLV
- LSN300HLV
- LSN360HLV

# ELECTRICAL WIRING

## Outdoor Unit Electrical Connections

### Terminal Block Connection for HV3

See Figure 101 for specific terminal block wiring for all following Single Zone outdoor unit models:

- LSU307HV3
- LSU360HV3

### Terminal Block Connections for 181HSV3 and 240HSV3

See Figure 101 for 181HSV3 and 240HSV3 Single Zone terminal block connections. The connections are identical to the HV3 outdoor units.

Figure 101: HV3 and 181HSV3, 240HSV3 Outdoor Unit - Electrical Connections

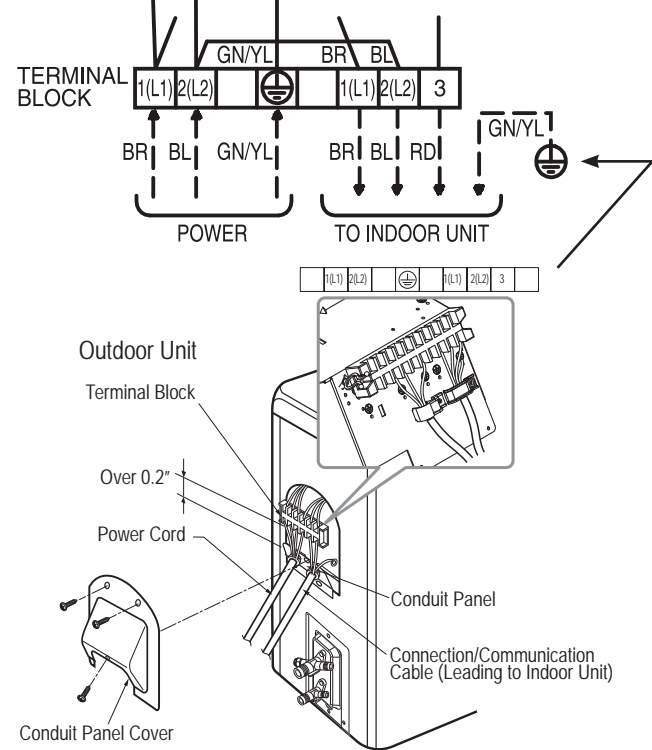

### Terminal Block Connection for 091HSV3, 121HSV3

See Figure 102 for specific terminal block wiring for all following Single Zone outdoor unit models:

- LSU091HSV3
- LSU121HSV3

Figure 102: 091HSV3, 121HSV3 Outdoor Unit - Electrical Connections

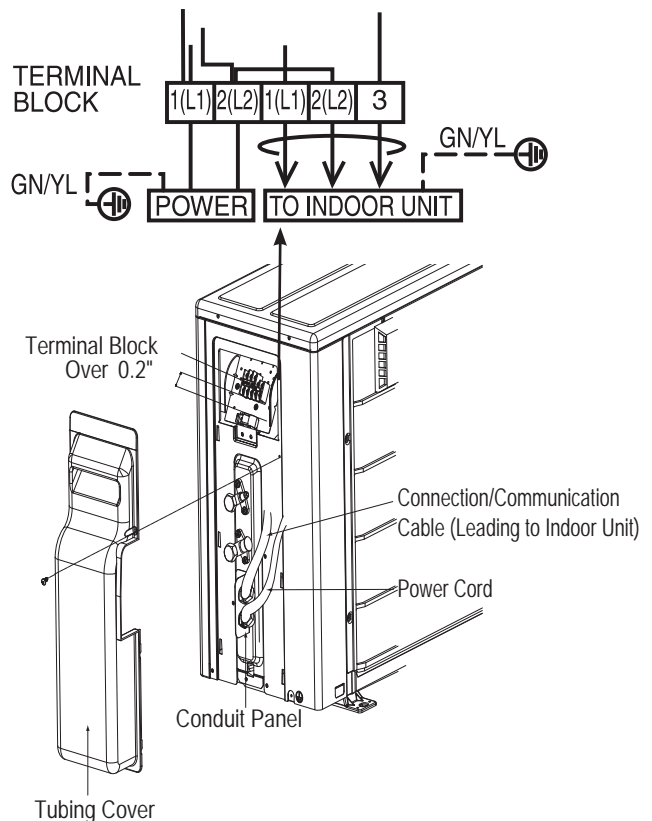

# ELECTRICAL WIRING

## Outdoor Unit Electrical Connections

### Terminal Block Connection for 090HEV, 090HEV1, 120HEV, 120HEV1

See Figure 103 for specific terminal block wiring for all following Single Zone outdoor unit models:

- LSU090HEV
- LSU090HEV1
- LSU120HEV
- LSU120HEV1

Figure 103: 090HEV, 090HEV1, 120HEV, 120HEV1 Outdoor Unit - Electrical Connections

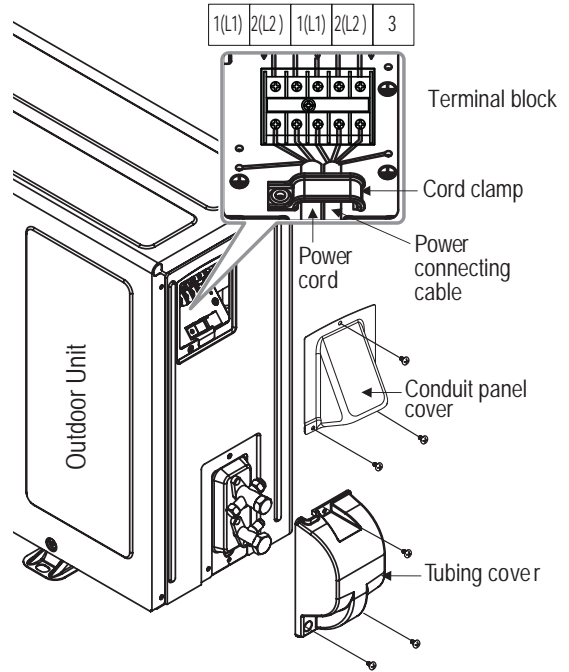

### Terminal Block Connection for 180HEV

See Figure 104 for specific terminal block wiring for all following Single Zone outdoor unit models:

- LSU180HEV

Figure 104: 180HEV Outdoor Unit - Electrical Connections

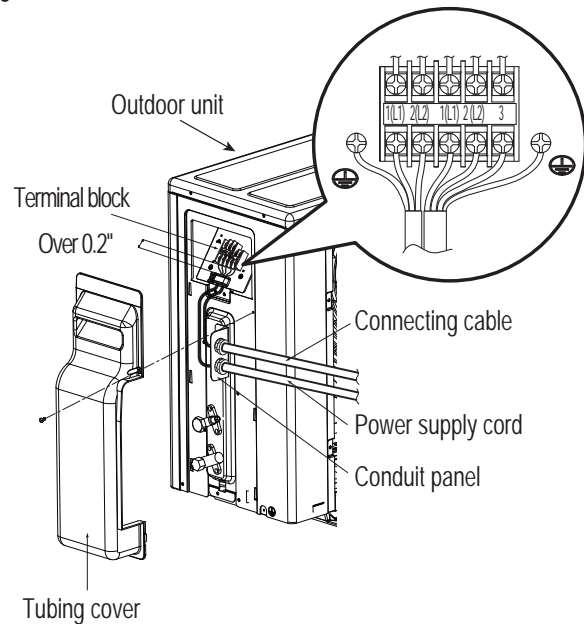

# ELECTRICAL WIRING

## Outdoor Unit Electrical Connections

### Terminal Block Connection for 180HEV1

See Figure 105 for specific terminal block wiring for all following Single Zone outdoor unit models:  
LSU180HEV1

Figure 105: 180HEV1 Outdoor Unit - Electrical Connections

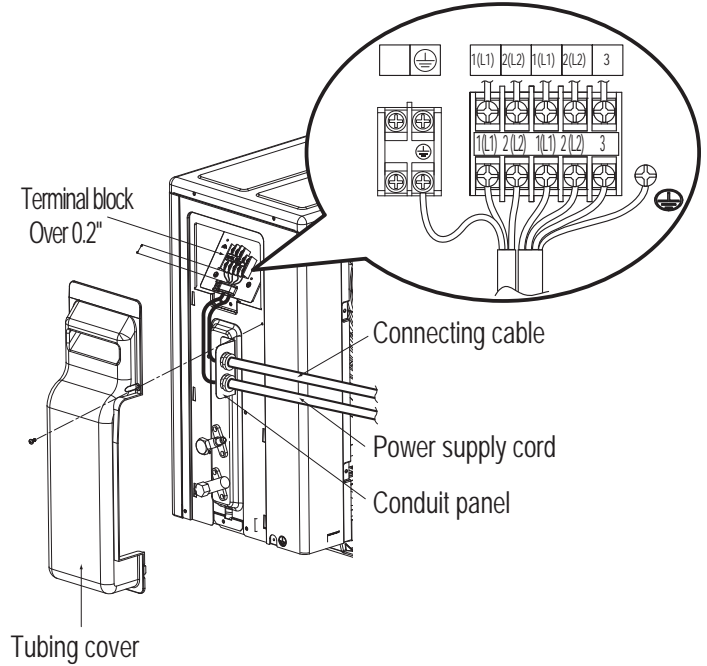

### Terminal Block Connection for 240HEV

See Figure 106 for specific terminal block wiring for the following Single Zone outdoor unit model:  
LSU240HEV

Figure 106: 240HEV Outdoor Unit - Electrical Connections

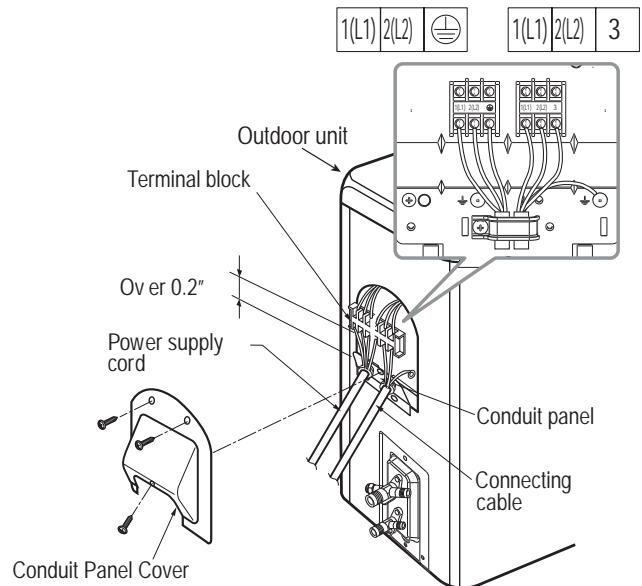



# ELECTRICAL WIRING

## Outdoor Unit Electrical Connections

### Terminal Block Connection for 240HEV1

See Figure 107 for specific terminal block wiring for the following Single Zone outdoor unit model:  
LSU240HEV1

Figure 107: 240HEV1 Outdoor Unit - Electrical Connections

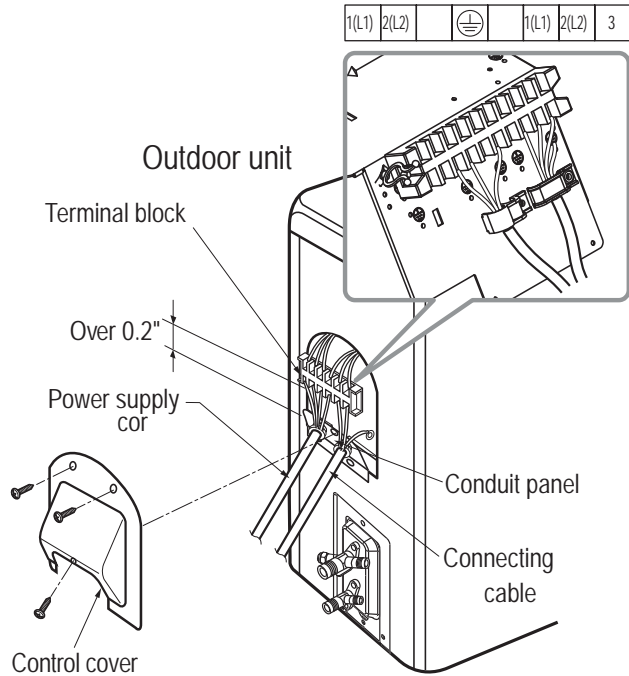

### Terminal Block Connection for HXV

See Figure 108 for specific terminal block wiring for all following Single Zone outdoor unit models:  
LSN090HXV  
LSN120HXV

Figure 108: 090HXV, 120HXV Outdoor Unit - Electrical Connections

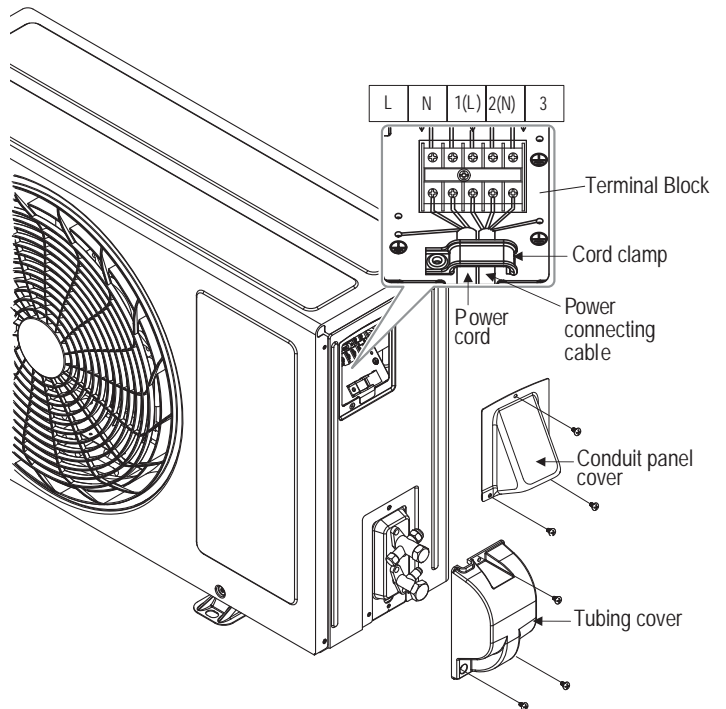

# ELECTRICAL WIRING

## Self Diagnosis Functions

### LG Monitoring View (LGMV) Diagnostic Software

LGMV software (PRCTSL1 and PRCTFE1) allows the service technician or commissioning agent to connect a computer USB port to the Single Zone system's main printed circuit board (PCB) using an accessory cable without the need for a separate interface device. The monitoring screen for LGMV allows the user to view the following real time data on one screen (Figure 109):

- Actual inverter compressor speed
- Target inverter compressor speed
- Actual outdoor fan speed
- Target outdoor unit fan speed
- Actual superheat
- Target superheat
- Actual subcooler circuit superheat
- Target subcooler circuit superheat
- Main EEV position
- Subcooling EEV position
- Inverter compressor current transducer value
- Outdoor air temperature
- Actual high pressure/saturation temperature
- Actual low pressure/saturation temperature
- Suction temperature
- Inverter compressor discharge temperature
- Front outdoor coil pipe temperature
- Back outdoor coil pipe temperature
- Liquid line pipe temperature
- Subcooler inlet temperature
- Subcooler outlet temperature
- Average indoor unit (IDU) pipe temperature
- Inverter compressor operation indicator light
- Liquid injection valves' operation indicator lights
- Hot gas bypass valve operation indicator light
- Four-way reversing valve operation indicator light
- Pressure graph showing actual low pressure and high pressure levels
- Error code display
- Operating mode indicator
- Target high pressure
- Target low pressure
- PCB (printed circuit board) version
- Software version
- Installer name
- Model number of IDUs
- Site name
- Total number of connected IDUs

Figure 109: MV Real-time Data Screen



- Communication indicators
- IDU capacity
- IDU operating mode
- IDU fan speed
- IDU EEV position
- IDU room temperature
- IDU inlet pipe temperature
- IDU outlet pipe temperature
- IDU error code

Additional screens can be accessed by tabs on the main screen.

Additional screens include the following:

1. Cycleview (Figure 110): Graphic of internal components including:
  - Compressors showing actual speeds
  - EEVs
  - IDUs
  - Temperature and pressure sensors
  - Four-way reversing valve
2. Graph: Full screen graph of actual high and low pressures and high and low pressure limits. A sliding bar enables user to go back in time and view data.
3. Control FTN: Enables user to turn on IDUs in 1.8 °F increments.
4. Useful Tab
  - Unit Conversion: Converts metric values to imperial values.

Figure 110: MV Cycleview

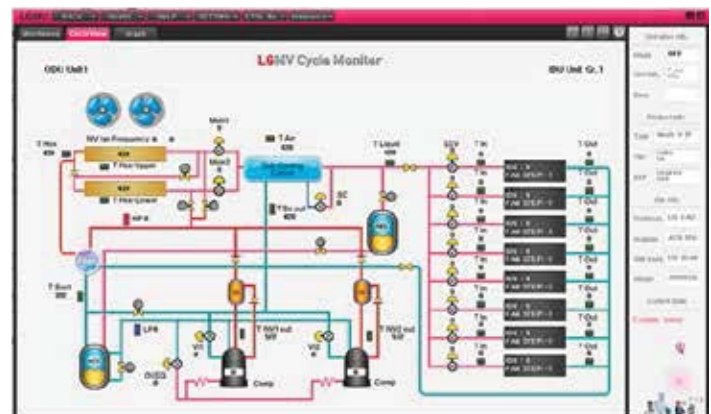

#### Note:

Images on these pages are examples of LGMV screenshots. Actual images may differ depending on the version of the software and the unit installed.

### LG Monitoring View (LGMV) Diagnostic Software and Cable - Continued

#### 5. Data (Figure 111)

- Data Saving Start: Recording of real time data to a separate file created to be stored on the user's computer.
- Data Loading Start: Recorded data from a saved ".CSV" file can be loaded to create an LGMV session.

#### 6. Monitoring

- Electrical: The lower half of main screen is changed to show Inverter Compressor Amps, Volts, Power Hz, Inverter control board fan Hz.

Figure 111: MV Control Indoor Units Screen



## Error Codes

LGMV software helps the service technician or commissioning agent to troubleshoot system operation issues by displaying malfunction codes (Figure 112). These error codes can be seen on the main screen of the LGMV software program. For an overview of Single Zone unit error codes, see Error Codes section. For detailed information on how to troubleshoot individual error codes, see the Single Zone Service Manual.

Figure 112: Error Code Screen



The software is available in a high version with all of the features listed above. The low version has all features as the high version without Target High Pressure and Target Low Pressure values shown on main screen.

In lieu of connecting to the outdoor unit, user has the option to connect to IDU with the use of a USB to RS-485 connector kit. When connected through IDU, user will not be able to record data.

This software can be used to both commission new systems and troubleshoot existing systems. LGMV data can be recorded to a ".CSV" file and emailed to an LG representative to assist with diagnostic evaluations.

### Recommended Minimum PC Configuration:

- CPU: Pentium® IV 1.6 GHz
- Main Memory: 1G
- Operating System: Windows® XP/Vista/7 32 bit (recommended), 64 bit
- Hard Disk: 600 MB when operating
- MS Office 2003, 2007 (recommended) for select reporting functions

### Note:

Images on these pages are examples of LGMV screenshots. Actual images may differ depending on the version of the software and the units installed.

# ELECTRICAL WIRING

## LG SIMS - Self Diagnosis Functions

The SIMs WLAN module and the smart phone app together provide monitoring and troubleshooting capability for LG Duct Free Systems. SIMs functions only with LG Duct Free products (Figure 113).

SIMS can display and graph operational data for the air conditioner system including the indoor unit and the outdoor unit. SIMs also displays error codes and a troubleshooting guide. A full copy of the LG SIMs Smart Inverter Monitoring System User's Manual is available on the [www.lghvac.com](http://www.lghvac.com) website.

To use SIMs you must be a trained HVAC service technician familiar with variable refrigerant flow (VRF) systems in general and with LG's Duct Free System products. You should understand the inverter air conditioning operation cycle, the meaning of the data displayed by SIMs, and how to use the data to troubleshoot the system.

Figure 114 shows a Multi F configuration used with the SIMs module and app. LG SIMs can also be used with Single Zone one-to-one configurations such as the Single Zone Wall Mount systems.

### ⚠ WARNING

High voltages capable of causing death are used in this equipment. Outdoor unit power remains connected during this procedure. Take extreme caution not to touch electrical components or connections. Failure to observe this warning can result in death or severe injury.

### Note:

- The Duct Free System air conditioning system must run for at least 15–20 minutes before data collected by SIMs 2.0 is valid for troubleshooting.
- You must have the free SIMs app correctly installed on your smart phone before using SIMs.
- Some ODUs have an LGMV extension cable accessed by removing the side handle cover. If the ODU does not have this extension cable, access the LGMV connector by removing the top cover of the ODU.

### SIMS App Main Info Screen

The main screen is the first screen displayed after wireless connection is established. Tap the Main Info tab to display current readings regarding your indoor and outdoor unit(s). The Operational Info area of the screen will show active functions or modes by illuminating the light to the right of the function (Figure 115).

Additional Help information can be accessed by tapping the Help Menu buttons at the bottom of this screen.

Figure 113: LG SIMs App and WLAN Module



Figure 114: SIMs WLAN Module to Typical DFS System



Figure 115: SIMs App Main Info Screen

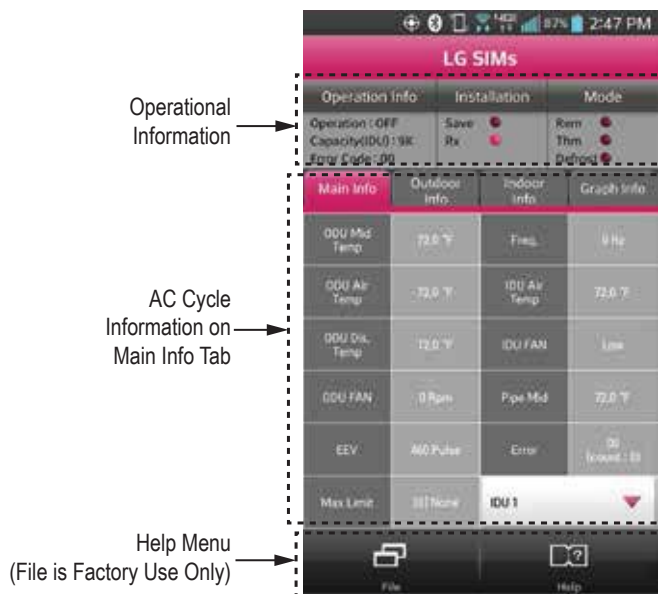

# ELECTRICAL WIRING

## LG SIMS - Self Diagnosis Functions

### SIMs App Screens



**Outdoor Info/Component Screen**  
Displays the following information:

- Frequency
- FAN1 RPM
- FAN2 RPM
- DC Link
- Current
- Voltage
- EEV Mode
- Restart Timer
- Comp Mode
- EEV

**Outdoor Info/Temperature Screen**

Displays the following information:

- Inv TD
- Suction
- Discharge
- Cond Mid
- Cond Out
- Heatsink
- Air Temp



**Indoor Info Tab**  
Displays the following information:

- Frequency
- Operation
- THM Mode
- REM Mode
- FAN
- EEV
- Air Temp
- Pipe-in
- Pipe-mid
- Pipe-out

**Graph Info Tab**

This tab, has three sub sections:

- IDU - Indoor Unit Temperature graph. Displays IDU information in graph format. Information displayed is for the IDU # selected on the Main screen.
- ODU - Outdoor Unit Temperature and Frequency graph. Displays ODU information in graph format.
- ODU Electric - Outdoor Unit Electric data graph is displayed.

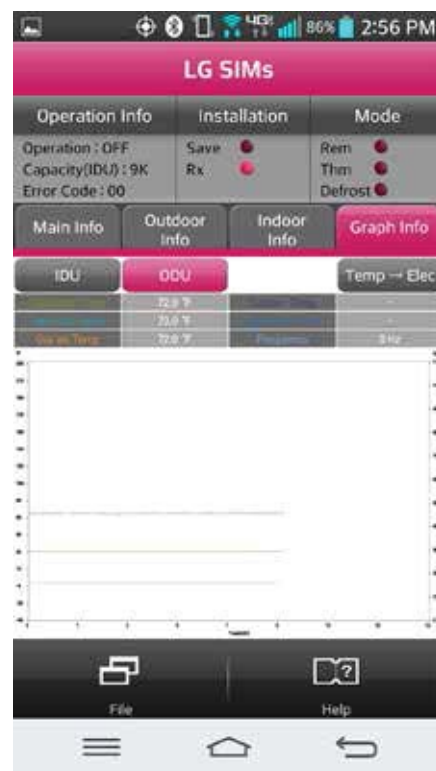

# TROUBLESHOOTING

## Error Codes

### Troubleshooting Using Error Codes

Refer to Table 35 and Table 36 for error codes that are generated from the indoor and outdoor units. These codes are the most common that will manifest through these units. Your particular model duct free system might generate additional codes not listed here. Please contact LG Support if you see these types of errors and a simple power down and boot up has not corrected the issue. You should not attempt to fix the system yourself.

#### Error Codes

- Refer to the figures below for your particular indoor unit's LED configuration.
- Indicate different types of unit failures, assists in self-diagnosis and to track the frequency of occurrence.

- Error codes are shown on the LEDs of indoor units, wired remote controller, the Single Zone unit control board, and LG Monitoring View (LGMV) Diagnostic Software.
- If two or more errors occur simultaneously, the lower error code number is displayed first.
- After error is resolved, the error code does not display.

#### Decoding the Error Display

The first and second number on the LED indicates error number. Example: 21 = LED1 (Green light) 2x blink, LED2 (Red light) 1x blink

#### Error Code Nomenclature Definitions

- MICOM: Non-volatile memory chip where unit setup information is stored.
- EPROM: Non-volatile memory chip where device identification, size, and factory defined default component operating parameters are stored.

Table 35: Single Zone Wall Mounted Indoor Unit Error Codes

Error Code	Description	No. of Times Indoor Unit LEDs Blink	
		LED1 (Plasma LED)	LED2 (Power LED)
1	Indoor unit room temperature sensor error	1X	-
2	Indoor unit inlet pipe sensor error	2X	-
4	Float switch error (optional)	4X	-
5	Communication error between indoor unit and outdoor units	-	5X
6	Indoor unit outlet pipe sensor error	6X	-
9	Indoor unit EPROM error	9X	-
10	Indoor unit BLDC motor fan lock	-	1X
12	Indoor unit middle pipe sensor error	2X	1X

Figure 116: IDU LS-HSV3 Models

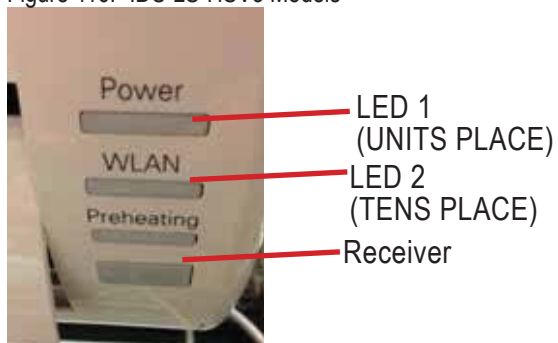

Figure 118: IDU LS-HV3/Some HSV Models

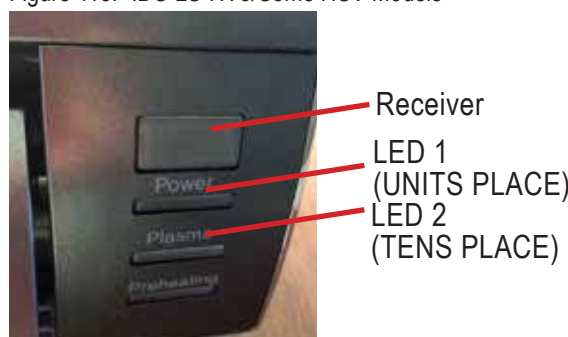

Figure 117: IDU Some HSV Models

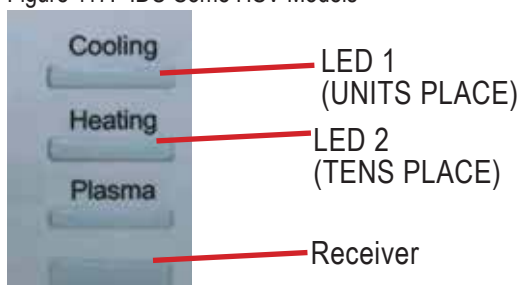
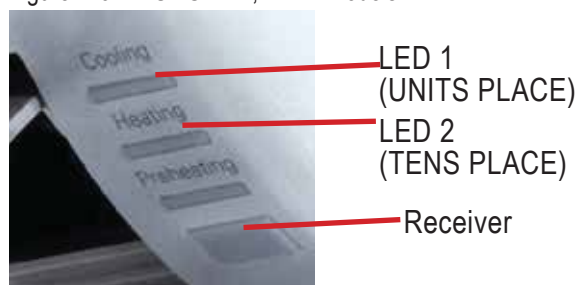

Figure 119: IDU LS-HEV, HEV1 Models



### Troubleshooting Using Error Codes - Continued

Table 35: Single Zone Wall Mounted Indoor Unit Error Codes - Continued

Error Code	Description	No. of Times Indoor Unit LEDs Blink	
		LED1 (Plasma LED)	LED2 (Power LED)
21	DC Peak (IPM Fault); Compressor DC voltage was too high	2X	1X
22	Current Transformer2 (CT2) error; Alternating current (AC) input too high	2X	2X
23	DC Link Low Volt	2X	3X
25	AC Low/High Volt	2X	5X
26	DC Comp Position Error (not providing rotation), Locking	2X	6X
27	PSC Fault; Current to inverter compressor between AC and DC converter circuit too high	2X	7X
28	Inverter compressor DC voltage is too high	2X	8X
29	Inverter compressor amperage is too high	2X	9X
31	Current-to-current transformer (CT) thermistor is too low	3X	1X
32	Inverter Compressor Discharge Pipe (D-Pipe) Overheat	3X	2X
40	CT Sensor Error; Thermistor is disconnected or shorted out	4X	-
41	D-Pipe Sensor INV is disconnected or shorted out	4X	1X
44	Outdoor Air Sensor is disconnected or shorted out	4X	4X
45	Middle thermistor of outdoor unit condenser coil is disconnected or shorted out	4X	5X
46	Outdoor unit suction line thermistor is disconnected or shorted out	4X	6X
48	Outdoor unit coil outlet (liquid line) thermistor is disconnected or shorted out	4X	8X
53	Communication failure from outdoor unit to indoor unit	5X	3X
60	Outdoor unit printed circuit board (PCB) EPROM check sum error	6X	-
61	Outdoor unit condenser coil temperature is too high	6X	1X
62	Outdoor unit inverter compressor PCB heat sink temperature is too high	6X	2X
63	Condenser coil pipe thermistor temperature is too low	6X	3X
65	Heat sink thermistor has disconnected or has shorted out	6X	5X
67	Outdoor brushless direct current (BLDC) fan motor lock error	6X	7X

Refer to Service Manuals posted on [www.lghvac.com](http://www.lghvac.com) for a full description of all error codes and work-arounds.

# TROUBLESHOOTING

## Error Codes

### Single Zone Wall Mounted Outdoor Unit Error Codes

The Single Zone Wall Mounted outdoor unit error codes are visible on the outdoor unit, as well as from the indoor unit. However, the indoor unit error codes are only visible from the indoor unit and will not display at the outdoor unit. When troubleshooting the system, be sure to verify if the error codes that are being displayed are specific for indoor or outdoor units.

Table 36: Single Zone Wall Mounted Outdoor Unit Error Codes

Error Code	Description	No. of Times Outdoor Unit LEDs Blink	
		LED1 (Plasma LED)	LED2 (Power LED)
21	DC Peak (IPM Fault); Compressor DC voltage was too high	2X	1X
22	Current Transformer2 (CT2) error; Alternating current (AC) input too high	2X	2X
23	DC Link Low Volt	2X	3X
25	AC Low/High Volt	2X	5X
26	DC Comp Position Error (not providing rotation), Locking	2X	6X
27	PSC Fault; Current to inverter compressor between AC and DC converter circuit too high	2X	7X
28	Inverter compressor DC voltage is too high	2X	8X
29	Inverter compressor amperage is too high	2X	9X
31	Current-to-current transformer (CT) thermistor is too low	3X	1X
32	Inverter Compressor Discharge Pipe (D-Pipe) Overheat	3X	2X
40	CT Sensor Error; Thermistor is disconnected or is shorted out	4X	-
41	D-Pipe Sensor INV is disconnected or shorted out	4X	1X
44	Outdoor Air Sensor is disconnected or shorted out	4X	4X
45	Middle thermistor of outdoor unit condenser coil is disconnected or shorted out	4X	5X
46	Outdoor unit suction line thermistor is disconnected or shorted out	4X	6X
48	Outdoor unit coil outlet (liquid line) thermistor is disconnected or shorted out	4X	8X
53	Communication failure from outdoor unit to indoor unit	5X	3X
60	Outdoor unit printed circuit board (PCB) EPROM check sum error	6X	-
61	Outdoor unit condenser coil temperature is too high	6X	1X
62	Outdoor unit inverter compressor PCB heat sink temperature is too high	6X	2X
63	Condenser coil pipe thermistor temperature is too low	6X	3X
65	Heat sink thermistor has disconnected or has shorted out	6X	5X
67	Outdoor brushless direct current (BLDC) fan motor lock error	6X	7X

Refer to Service Manuals posted on [www.lghvac.com](http://www.lghvac.com) for a full description of all error codes and work-arounds.



# CAUTIONS FOR REFRIGERANT LEAKS

## Refrigerant Leaks

### Cautions for Refrigerant Leaks / Introduction

ASHRAE Standards 15-2010 and 34-2010 offer guidelines that address refrigerant safety and the maximum allowable concentration of refrigerant in an occupied space. Refrigerant will dissipate into the atmosphere, but a certain volume of air is required for this to occur safely. For R410A refrigerant, the maximum allowable concentration is 0.026 lbs./ft<sup>3</sup> per 1,000 ft<sup>3</sup> of air in an occupied space. Buildings with twenty-four (24) hour occupancy allow half of that concentration.<sup>1</sup>

ASHRAE Standards 15 and 34 assume that if a system develops a leak, its entire refrigerant charge will dump into the area where the leak occurs. To meet ASHRAE Standards 15 and 34, calculate the refrigerant concentration that may occur in the smallest room volume on the system, and compare the results to the maximum allowable concentration number (see below for information on how to calculate the refrigerant concentration).<sup>1</sup> Also consult state and local codes in regards to refrigerant safety.

#### **⚠ WARNING**

Verify the maximum refrigerant concentration level in the space where the indoor unit will be mounted meets the concentration limit for the application. If the refrigerant leaks and safety limits are exceeded, it could result in personal injuries or death from oxygen depletion.

#### **Note:**

Take appropriate actions at the end of HVAC equipment life to recover, recycle, reclaim or destroy R410A refrigerant according to applicable US EPA rules.

To calculate the potential refrigerant concentration level (RCL):

1. Measure the occupied space dimensions (in feet).
2. Calculate the cubic foot volume of air in the smallest occupied space. (To obtain a detailed overview of the RCL, perform the same calculations to the second smallest zone, the third smallest zone until the RCL is obtained for all zones. Also, pay special attention to areas such as basements, etc., where refrigerant cannot dissipate easily.)
3. Divide the refrigerant charge of the Single Zone system serving the area in pounds by the results of step 1.
4. If the calculation indicates that the potential refrigerant concentration level is higher than the allowed RCL, increase the cubic volume of the smallest occupied space or modify the piping system design.
5. The allowable RCL limit for most applications must be equal to or less than 0.026 lbs./ft<sup>3</sup>. However, in special occupied spaces, such as hospitals and nursing homes, where occupants may have limited mobility, the allowable RCL limit is cut in half. See ASHRAE Standard 34-2007 and local codes for detailed information.<sup>1</sup>

#### Refrigerant Concentration Limit (RCL) Calculations

To calculate total refrigerant amount per system:

Amount of Factory-Charged Refrigerant per Outdoor Unit	+	Amount of Additional Refrigerant Trim Charge	=	Total System Refrigerant Charge
---	---	---	---	---------------------------------------

$$\text{RCL (lbs./ft}^3\text{)} = \frac{\text{Total System Refrigerant Charge (lbs.)}}{\text{Volume of Smallest Occupied Space (ft}^3\text{)}}$$

<sup>1</sup> American Society of Heating, Refrigeration and Air Conditioning Engineers, Inc. (ASHRAE). Atlanta, GA. ASHRAE, Inc. Information about ASHRAE Standard 15-2010 / 34-2010 and addenda current as of the date of this publication.

# INSTALLATION CHECKLIST

PAGE 1

## Major Component Rough-In

Description	Check
Single Zone unit was connected properly per local code and the product installation procedures.	
All literature and bagged accessories have been removed from the fan discharge.	
Indoor unit was installed, properly supported, and located indoors in a non-corrosive environment.	
Single Zone unit's gravity condensate drain line was connected and routed where it properly drains away or, if installed in a mechanical room, was connected and properly routed to a drain terminal.	

## Piping and Insulation

Description	Check
Copper	
Over 5/8 inches—Rigid ACR only.	
5/8 inches and under—Can use soft ACR.	
15% silver brazing material only.	
All refrigerant pipes and valves were insulated separately. Insulation butts up against the walls of the indoor units. No gaps or cracks. Insulation was not compressed at clamps and hangers.	

## Brazing Practices

Description	Check
Medical grade (there are 4 available) dry nitrogen for purging during brazing was used (constant 3 psi while brazing).	

## Installation

(For more information on any procedure, refer to the detail provided in the Indoor Unit Installation Manuals.)

## Refrigerant Piping

Description	Check
All pipe materials were properly stored, capped, and clean. All burrs were removed after cutting and pipe ends were reamed before brazing.	
During refrigerant pipe installation, for each segment of pipe, a record was made of the pipe length (including expansion loops, offsets, double-back sections), and sizes, as well as the quantity and type of elbows used.	
All long runs of straight pipe were provided with expansion loops.	
A torque wrench and backup wrench were used to tighten all flare connections.	
The back side of all flares were lubricated with a small drop of PVE refrigeration oil before tightening flare fittings.	
Ensure all field made flares are 45°. Use factory-supplied flare nuts only.	
Pipe segments were properly supported and all wall penetrations were sleeved.	
Pipe insulation was not compressed at any point.	
No oil traps, solenoid valves, sight glasses, filter driers, or any other unauthorized refrigerant specialties were present.	
Best practice including a minimum of 20" of straight pipe was installed between each elbow.	

# INSTALLATION CHECKLIST

PAGE 2

## Condensate Pump / Drain Installation Power Wire and Communications Cables

Description	Check
Power wiring was connected to a single phase 208-230V source or 115V (Mega 115 HXV models only).	
Ground wire was installed and properly terminated at the unit.	
The power supplied was clean with voltage fluctuations within specifications. ( $\pm 10\%$ of nameplate).	
Power wiring to the Single Zone outdoor unit was installed per all local electrical code requirements.	
Power wiring to the indoor unit was installed per all local electrical code requirements.	
LG-supplied cable was used between the indoor unit and its zone controller. No cables were spliced and no wire caps are present.	
Communication type RS-485-BUS type.	
Communications/power were a minimum of 18-AWG, four (4) conductor, stranded, shielded or unshielded, with insulation material per local code. If shielded, must be ground to ODU only. Cable segment shields were tied together.	
Used appropriate crimping tool to attach ring or spade terminals at all power wiring and control cable terminations.	
Power and control wires were run in the same conduit (ODU to IDU only) as provided in the product installation manual. Power to ODU and power/communications to IDU cannot be run in the same conduit.	

For further technical materials such as submittals, engineering manuals, service manuals, and catalogs, visit [www.lghvac.com](http://www.lghvac.com).

*Inverter*



LG Electronics, U.S.A., Inc.  
Commercial Air Conditioning Division  
4300 North Point Parkway  
Alpharetta, Georgia 30022  
www.lg-vrf.com

LG Customer Information Center, Commercial Products  
1-888-865-3026 USA

Follow the prompts for commercial A/C products.

IM\_WallMounted\_All\_11\_15  
Supersedes IM\_WallMounted\_All\_08\_15  
IM-WallMounted-All-08-14.1